

UI Series

Pneumo-hydraulic cylinders

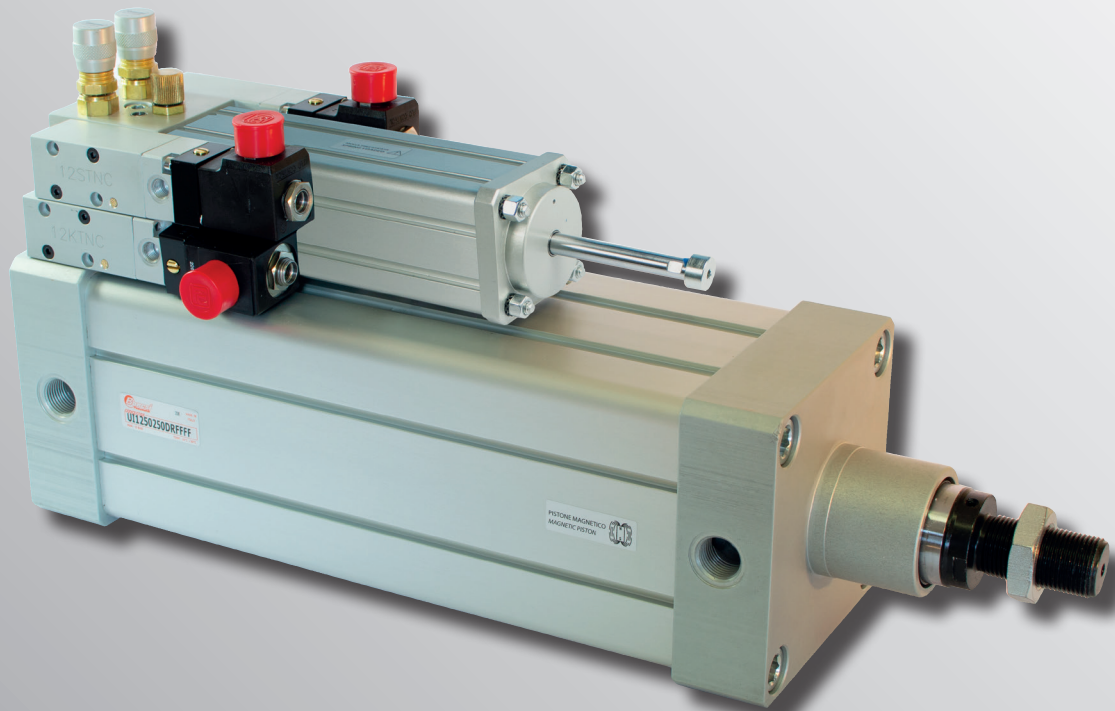

***Mounting dimensions
according to ISO 15552***

ISO 9001
BUREAU VERITAS
Certification

N° IT275286



Bonesi
Pneumatik



Pneumo-hydraulic cylinders with mounting dimensions according to ISO 1552 standards Series UI

Bores Ø : 50 - 63 - 80 - 100 - 125 mm.

SERIES UI

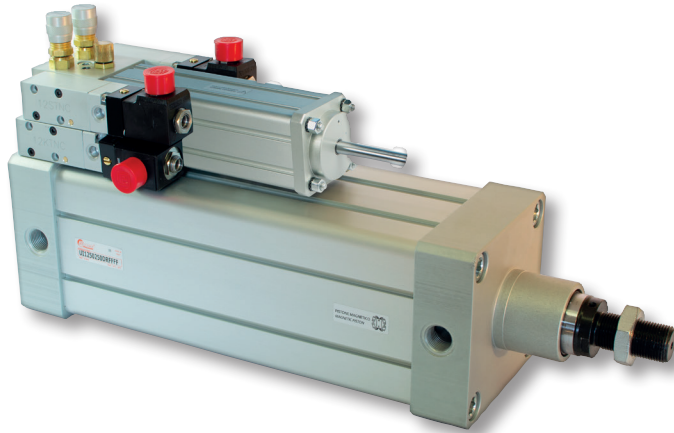

Pneumatic cylinder with dimensions according to ISO 1552 standards

Adjustment of the sliding speed and stop of the piston rod

SKIP and STOP valves 2/2 or 2/2 with regulator Solenoid or pneumatic actuated, NC/NO

Available the option of level sensor on the oil tank

End stroke hydraulic cushionings (not adjustable)

Caps in aluminium alloy neuter anodized

Profiled tube in anodized aluminium, internally gauged

Piston rod in steel E355, grounded and hard chromium plated

Piston in aluminium with magnetic ring

“T” grooves for sensors, on the side

Sensors and mounting accessories

TECHNICAL FEATURES

Construction	Caps fixed on profiled tube by bolts, hydraulic cushioning integrated
Function	Double acting
Standard materials	Caps in aluminium alloy neuter anodized, piston rod in steel E355 grounded and hard chromium plated, profiled tube in anodized aluminium, internally gauged, piston in aluminium, seals in NBR - PU.
Note about the materials	According to Directive REACH (1907/2006/CE and s.a.s.)
Bores	Ø 50, 63, 80, 100, 125 mm
Standard strokes at stock	50, 100, 150, 200, 250, 300, 350, 400, 500 mm
Standard strokes available on request	50 ÷ 1100 mm
Special strokes	To be agreed with the Commercial Department
Working temperature	0 + 50°C (-10°C with dry air in order to avoid ice formation)
Working pressure	2 ÷ 8 bar
Operating pressure of the valves	3,5 ÷ 8 bar
Fluid of the pneumatic circuit	Filtered air, without lubrication, according to ISO 8573-1:2010 [7:4:4]
Fluid of the hydraulic circuit	Hydraulic oil ISO 46
Speed	See the theoretical diagram of the speeds (page 2.1.05.5)

TECHNICAL DATA

Bore Ø (mm)	50	63	80	100	125
Ports	1/4"	3/8"	3/8"	1/2"	1/2"
Piston rod Ø (mm)	25	30	30	40	45
Thread of the piston rod	M16 x 1,5	M16 x 1,5	M20 x 1,5	M20 x 1,5	M27 x 2
Theoretical push force at 6 bar (N)	1110	1750	2895	4592	7242
Theoretical pull force at 6 bar (N)	884	1446	2592	3958	6409
Air consumption at 6 bar in push (NI/cm)	0,130	0,204	0,338	0,536	0,845
Air consumption at 6 bar in pull (NI/cm)	0,103	0,169	0,302	0,462	0,748
Theoretical speed at 6 bar in push (mm/sec)	530	560	650	250	220
Theoretical speed at 6 bar in pull (mm/sec)	160	170	215	150	175

THEORETICAL DIAGRAM OF THE FORCES AND OF THE AIR CONSUMPTIONS

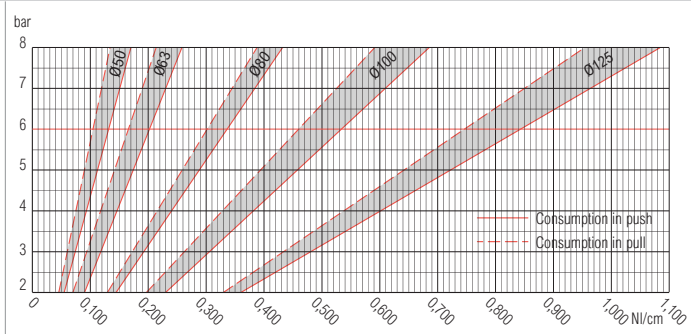
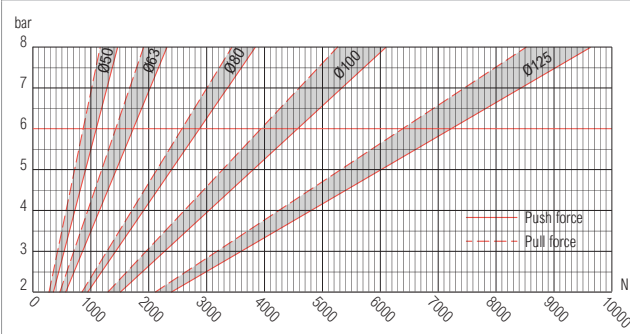

PNEUMO-HYDRAULIC UNITS SERIES UI

The widest range of pneumo-hydraulic units on the market

With the new series UI of pneumo-hydraulic units **BONESI PNEUMATIK** enlarges its range of hydraulic control units, developed and completely produced at its Italian headquarters, for the applications where an accurate handling of the working stroke is required.

The design features of such new series represent the summary of two applied techniques:

- The compressed air as driving power;
- The hydraulic system as control fluid.

The system offers several functions on the working strokes:

- Governed and steady speeds with changing workloads and inlet air pressure;
- Gradual end-stroke hydraulic cushionings to dissipate the dynamic mass energy;
- Functions of quick stroke (SKIP), regulated stroke and STOP on the forward and return strokes, manageable using electric or pneumatic impulses

UI version

Pneumatic cylinder with coaxial hydraulic control
Standard, magnetic, manifold group and tank mounted on the rear cap

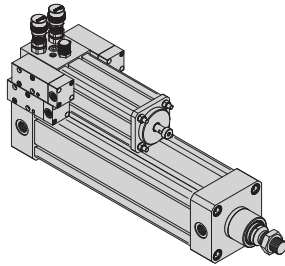

UT version

Pneumatic cylinder with coaxial hydraulic control
Standard, magnetic, manifold group and tank remoted

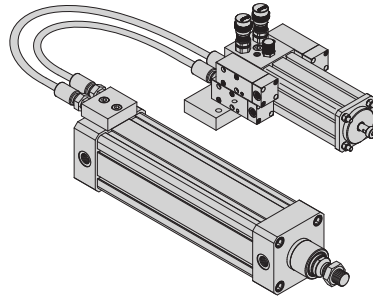

UB version

Pneumatic cylinder with coaxial hydraulic control
Standard, magnetic, manifold group mounted on the rear cap, tank remoted

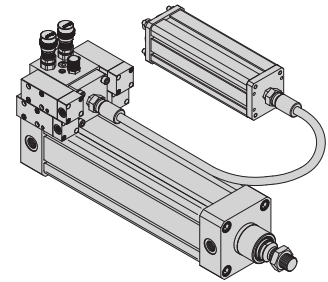

POS	DESCRIPTION	POS	DESCRIPTION
①	Units series UI	⑫	DOUBLE SKIP valve solenoid actuated with remoted speed adjustment
②	Units series UT	⑬	DOUBLE SKIP valve pneumatic actuated with remoted speed adjustment
③	Units series UB	⑭	Without STOP valves
④	Speed regulator	⑮	SKIP valve solenoid actuated
⑤	Speed regulator remoted on STOP valve	⑯	SKIP valve pneumatic actuated
⑥	Speed regulator remoted on SKIP valve	⑰	SKIP valve solenoid actuated with speed adjustment
⑦	Without speed regulators	⑱	SKIP valve pneumatic actuated with speed adjustment
⑧	STOP valve solenoid actuated	⑲	SKIP valve solenoid actuated with remoted speed adjustment
⑨	STOP valve pneumatic actuated	⑳	SKIP valve pneumatic actuated with remoted speed adjustment
⑩	DOUBLE SKIP valve solenoid actuated with speed adjustment	㉑	Without SKIP valves
⑪	DOUBLE SKIP valve pneumatic actuated with speed adjustment		

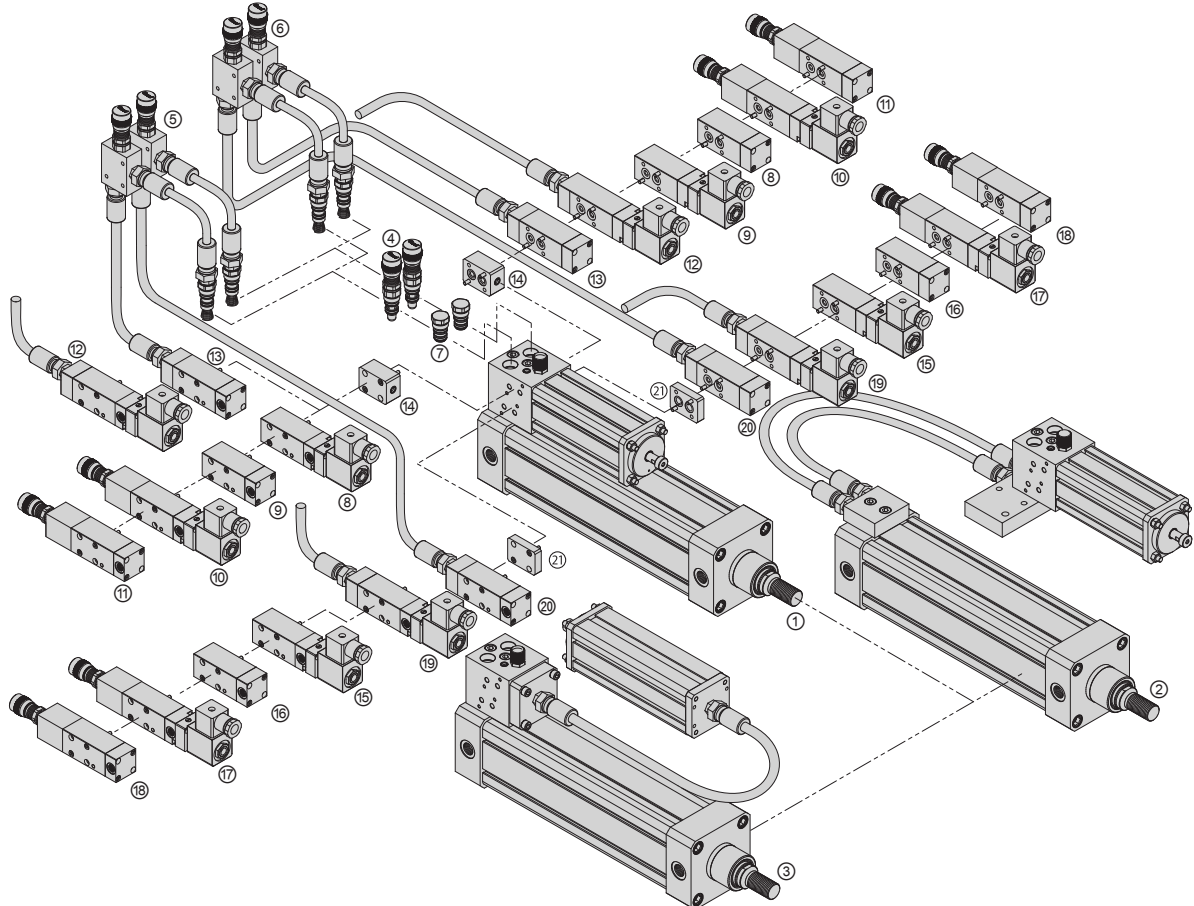

PRINCIPLES OF OPERATION OF THE SKIP AND STOP CONTROL VALVES

Wide possibility of configurations as standard

The new pneumo-hydraulic units series UI, proposed by **BONESI PNEUMATIK**, have a wide range of SKIP and STOP control valves that allow to customize the functions of the unit and to regulate the speed and the position of the piston rod during all the working stroke.

Thanks to an accurate technical design the functions of the pneumo-hydraulic unit can be customized by the customer placing the order and the consequent combining in the mounting of the SKIP and STOP control valves and of the speed regulators.

This allows an higher flexibility in the configurations, customizing the needs, still using components of standard production.

Here following some of the most common functions proposed by **BONESI PNEUMATIK**. For different needs, please, contact our technical-commercial staff.

UNIT WITH STOP FUNCTION VALVES

Hydraulic speed regulation separated in forward and return strokes. STOP function. Solenoid or pneumatic actuators, NC or NO.

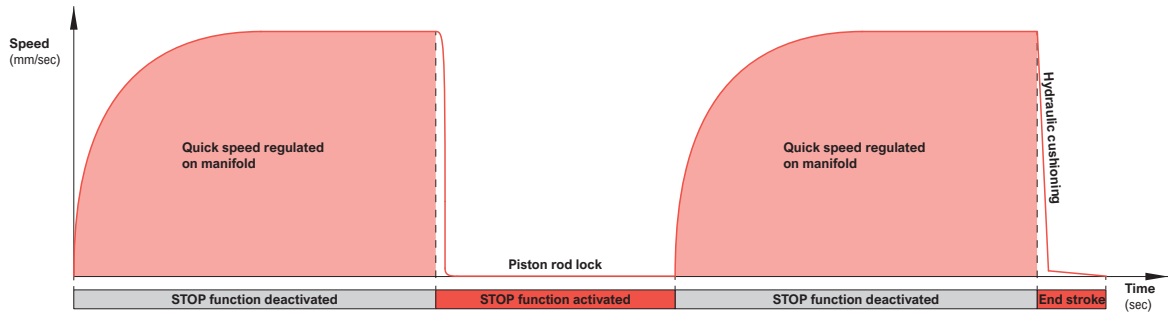
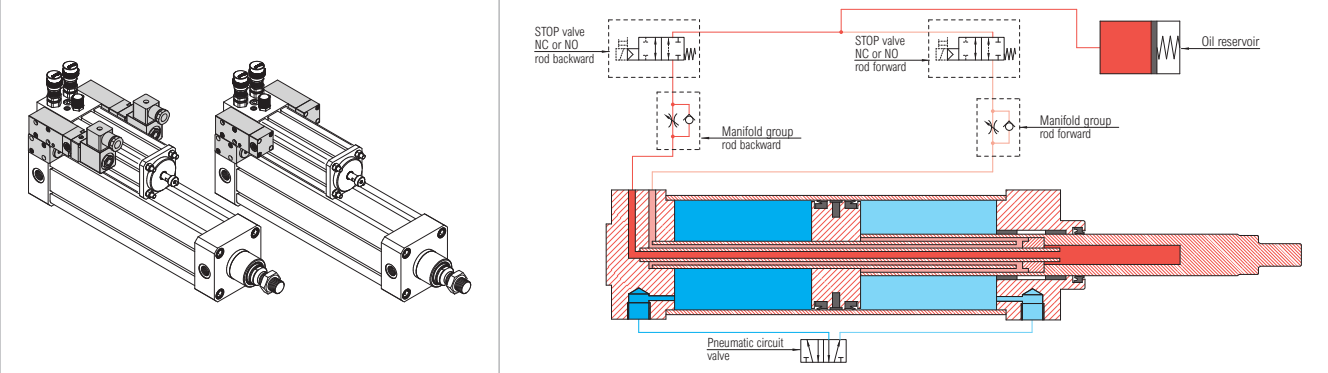

UNIT WITH STOP FUNCTION VALVES

Quick speed in forward and return strokes. SKIP function with hydraulic regulation of the speed separated in forward and return strokes. Solenoid or pneumatic actuators, NC or NO.

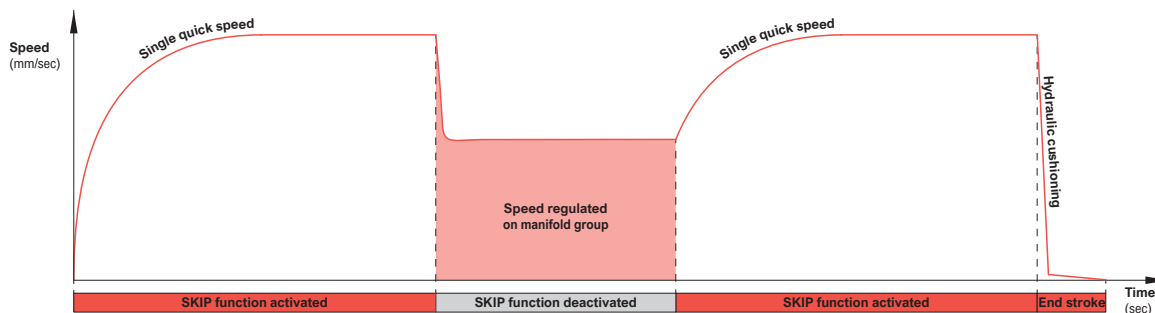
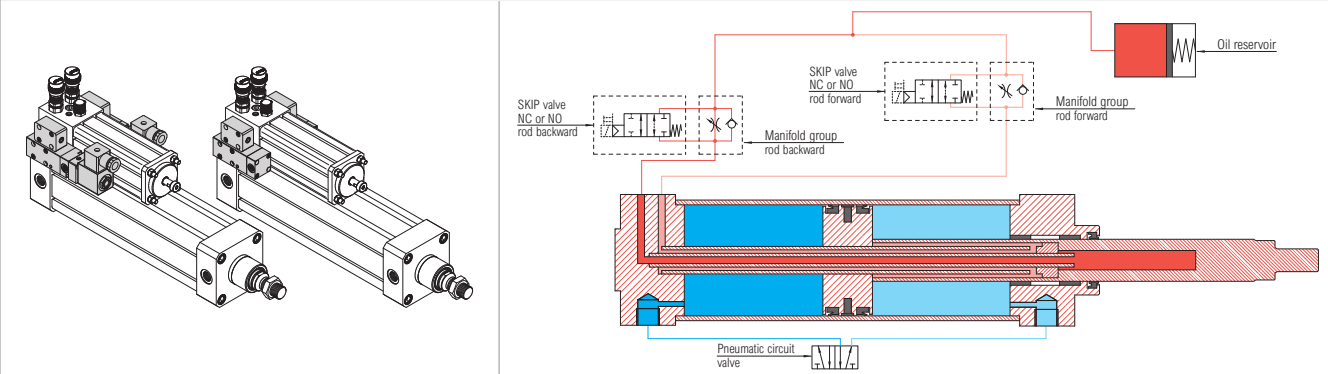

PRINCIPLES OF OPERATION OF THE SKIP AND STOP CONTROL VALVES

UNIT WITH SKIP AND STOP FUNCTION VALVES

Quick speed in forward and return strokes. SKIP function with hydraulic regulation of the speed separated in forward and return strokes. STOP function. Solenoid or pneumatic actuators, NC or NO.

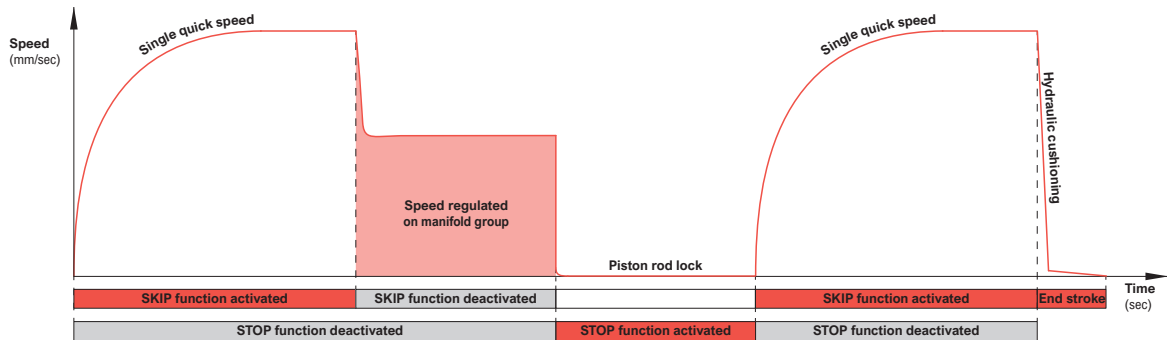
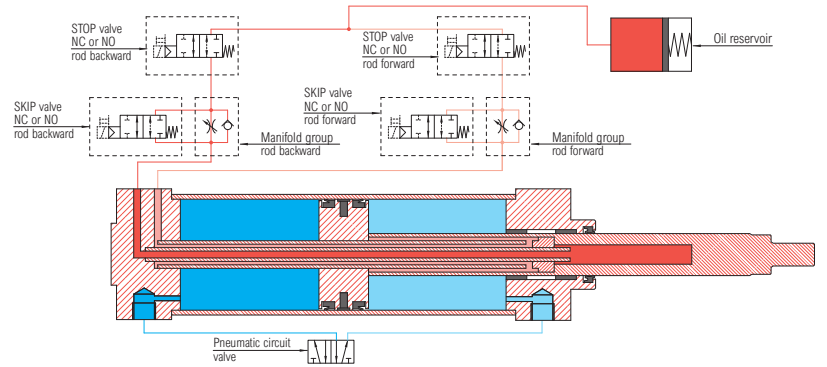
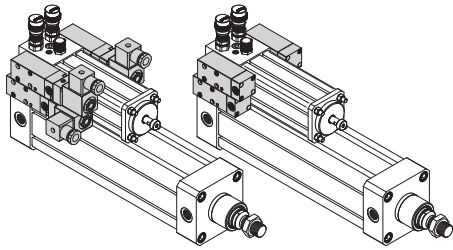

UNIT WITH ADJUSTABLE SKIP AND STOP FUNCTION VALVES

Double hydraulic speed regulation separated in forward and return strokes. STOP function. Solenoid or pneumatic actuators, NC or NO.

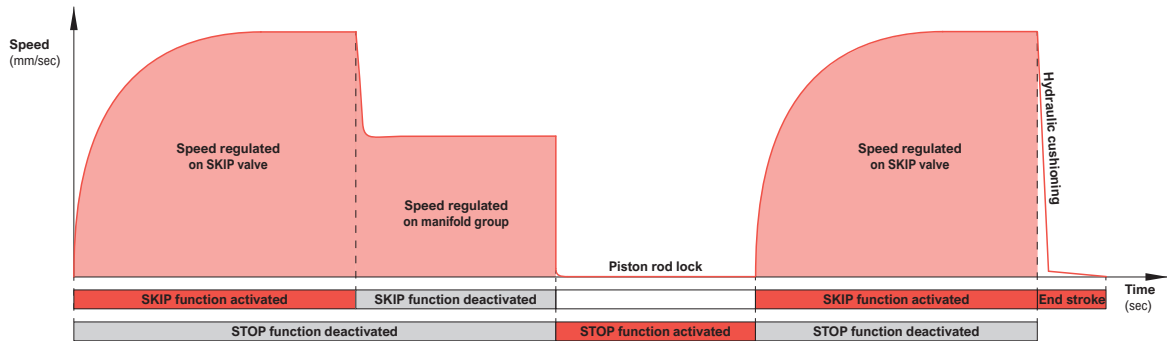
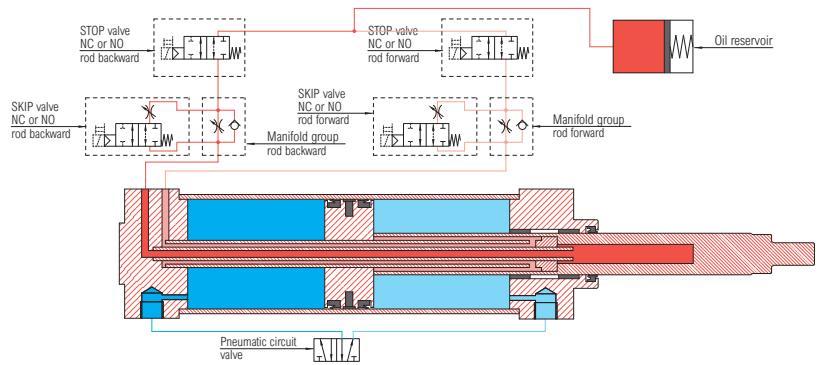
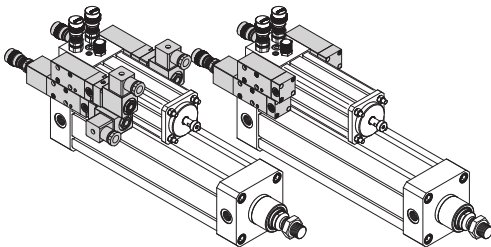

PRINCIPLES OF OPERATION OF THE SKIP AND STOP CONTROL VALVES

UNIT WITH DOUBLE ADJUSTABLE SKIP FUNCTION VALVES

Triple hydraulic speed regulation separated in forward and return strokes. Solenoid or pneumatic actuators, NC or NO.

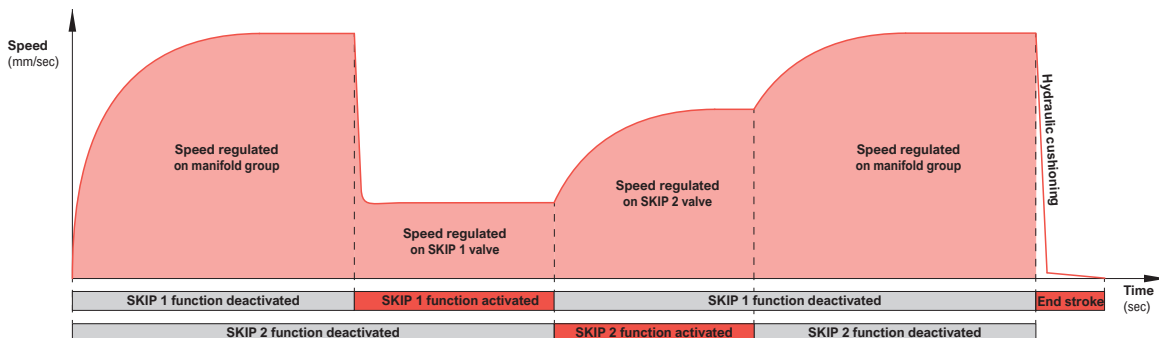
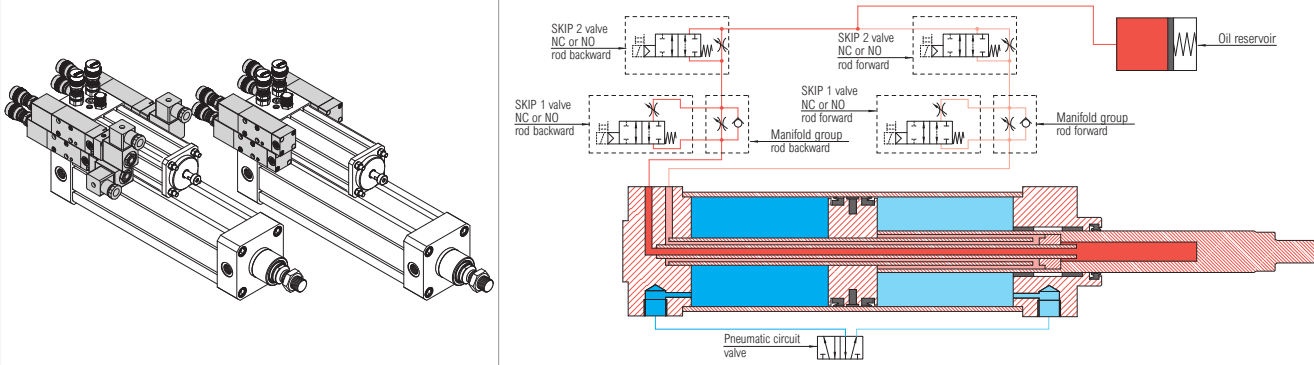

SPEED AND PRECISION OF POSITIONING

The average figures mentioned on the following diagrams give indications about the speed and stop stroke in function of the bore and the inlet pressure of the unit, at the ambient temperature of 20°C, with pneumatic inlet valves with nominal flow capacity equal to the connection on the caps of the unit.

Different ambient working conditions or particular pneumatic circuitings can produce values different from those mentioned on the diagrams.

It is suggested to use the STOP valve with a SKIP valve in order to reduce the speed near the stop position. This guarantees a constant stop position equal to ±0,3 mm with SKIP valve setted to 10 mm/sec.

Our technical staff is available for further explanations or to develop solutions more useful to the customer.

THEORETICAL DIAGRAM OF THE SPEEDS

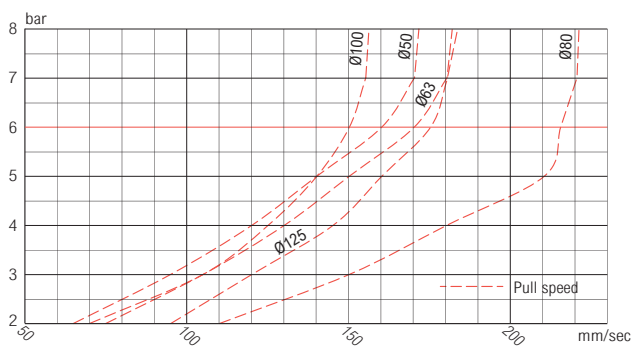
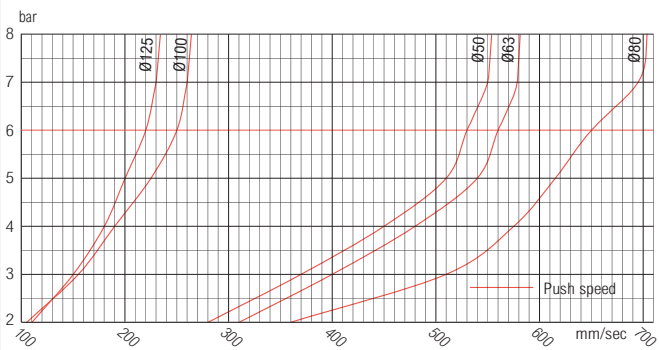

REGULATION OF THE SPEED STANDARD AND PRECISE

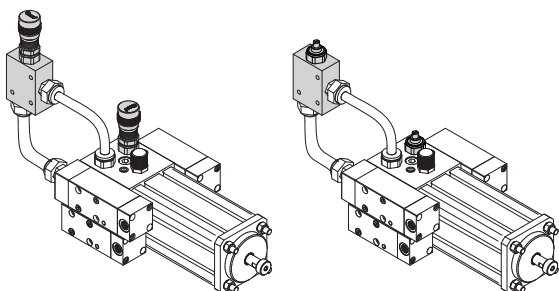

The pneumo-hydraulic UI units can be equipped with different types of hydraulic speed regulators.

All regulators can be supplied either in the version assembled on the manifold group or in the version remoted, for panel mounting or in case the pneumo-hydraulic unit is located in difficult position. In both cases, manifold or remoted, the regulators can be supplied with protrusion standard or reduced.

In case an higher precision in the regulation of the speed should be necessary, BONESI PNEUMATIK has developed a specific regulator (available exclusively with standard dimensions) that can be used either in the version assembled on the manifold or in the version remoted.

OPTIONS

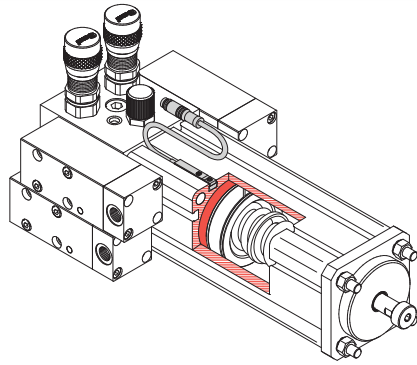

Control of oil level

All the **UI** pneumo-hydraulic units are equipped, as standard, of a level indicator at the end side of the tank that allows the quick control of the quantity of the oil in the tank.

The new **UI** pneumo-hydraulic units mounting a magnetic ring on the piston located inside the tank and by a sensor to send an electrical impulse to a controller of the oil level in the unit.

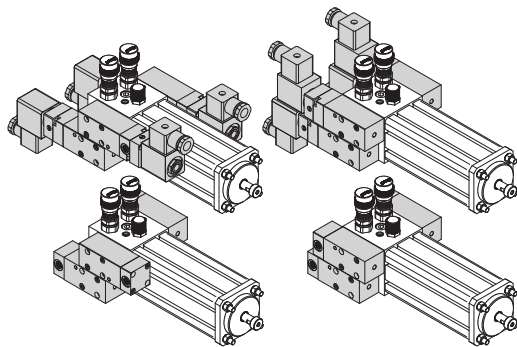

Customization in mounting the control valves

Advantage of the new **UI** series of pneumo-hydraulic units of **BONESI PNEUMATIK** is the possibility to customize the mounting of the SKIP and STOP valves, located on the side of the manifold group, in order to help the needs of the customer.

Unless different instructions placing the order the control and the regulation valves will be assembled reducing the dimension of the unit.

On the contrary : in agreement with the Commercial Department placing the order it is possible to specify a different assembling.

(On the side : some examples of assembling)

STANDARD MATERIALS

POS	DESCRIPTION	MATERIAL	POS	DESCRIPTION	MATERIAL
①	Caps	Aluminium alloy neuter anodized	⑫	Guide slidingig	Carbographite
②	Piston rod seal	Nitril rubber (NBR)	⑬	Piston rod nut	Zinc plated steel
③	Guide bushing	Steel + PTFE	⑭	Manifold group	Aluminium alloy neuter anodized
④	Cap seal	Nitril rubber (NBR)	⑮	Tank rod	C45 steel chromium plated 20 µm
⑤	Cap fixing bolt	Zinc plated steel	⑯	Tank nuts and tie-rods	Zinc plated steel
⑥	Actuator profiled tube	Extruded aluminium EN AW-6060 T6, gauged and anodized	⑰	Tank caps	Aluminium alloy neuter anodized
⑦	Piston rod	Chromium plated steel E355	⑱	SKIP and STOP valves	Aluminium alloy neuter anodized
⑧	End part of the piston rod	Manganese phosphatized steel	⑲	Plug	Brass EN 12164
⑨	Piston	Aluminium alloy	⑳	Regulation group	Brass EN 12164 + Aluminium alloy neuter anodized
⑩	Piston seal	Poliurethane (PU)	㉑	Magnet for control oil level	Plastoferrite
⑪	Magnet	Plastoferrite	㉒	Spring	Spring steel

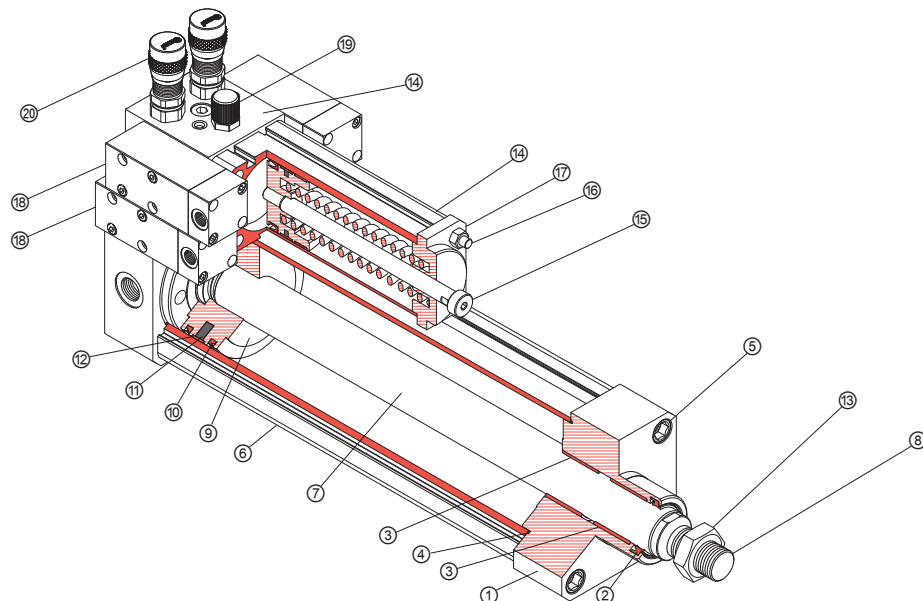



ORDERING CODE

Series	Bore	Rod stroke	Function	Speed regulation	STOP control valves		SKIP control valves		Pneumatic ports	Options
UI	050	0100	D	R	C	C	N	N	<input type="checkbox"/>	<input type="checkbox"/>

050 = Ø50
 063 = Ø63
 080 = Ø80
 100 = Ø100
 125 = Ø125

XXXX = Standard stroke
 (Special on request)

D = Double acting cylinder with double cushioning
U = Double acting cylinder with cushioning only on piston rod in forward
R = Double acting cylinder with cushioning only on piston rod in return
N = Double acting cylinder without cushionings

UI = Manifold group and tank mounted on the rear cap	
UT = Manifold group and tank removed ⁽¹⁾	
UB = Manifold group mounted on the rear cap, tank removed ⁽¹⁾	

OPERATED CONTROL VALVES STOP / SKIP	PN.	A = Pneumatic operated valve N.O. B = Pneumatic operated valve N.C.
	DIRECT CURRENT	C = Solenoid operated valve N.O. 12Vdc D = Solenoid operated valve N.C. 12Vdc E = Solenoid operated valve N.O. 24Vdc F = Solenoid operated valve N.C. 24Vdc G = Solenoid operated valve N.O. 48Vdc H = Solenoid operated valve N.C. 48Vdc I = Solenoid operated valve N.O. 110Vdc J = Solenoid operated valve N.C. 110Vdc
ALTERNATING CURRENT		K = Solenoid operated valve N.O. 24Vac L = Solenoid operated valve N.C. 24Vac M = Solenoid operated valve N.O. 48Vac P = Solenoid operated valve N.C. 48Vac Q = Solenoid operated valve N.O. 110Vac R = Solenoid operated valve N.C. 110Vac S = Solenoid operated valve N.O. 220Vac T = Solenoid operated valve N.C. 220Vac
		N = Without control valve

NULL = Standard (left side)
V = Double ports
Z = Triple ports

MANIFOLD STANDARD	R = Double hydraulic regulation
	S = Single hydraulic regulation, in forward
	T = Single hydraulic regulation, in return
	U = Double hydraulic regulation (compact size)
FINE	V = Single hydraulic regulation, in forward (compact size)
	Z = Single hydraulic regulation, in return (compact size)
	F = Double precise hydraulic regulation
REMOVED STANDARD	G = Single precise hydraulic regulation in forward
	H = Single precise hydraulic regulation in return
	A = Double hydraulic regulation ⁽²⁾
	B = Single hydraulic regulation, in forward ⁽²⁾
FINE	C = Single hydraulic regulation, in return ⁽²⁾
	W = Double hydraulic regulation (compact size) ⁽²⁾
	X = Single hydraulic regulation, in forward (compact size) ⁽²⁾
FINE	Y = Single hydraulic regulation, in return (compact size) ⁽²⁾
	I = Double precise hydraulic regulation ⁽²⁾
	L = Single precise hydraulic regulation, in forward ⁽²⁾
	M = Single precise hydraulic regulation. In return ⁽²⁾
	N = Without regulation

NULL = Standard
P = Customized
 • Customized mounting of the control valves
 • STOP/SKIP control valves with speed adjustment

⁽¹⁾ Standard length of the remote tubings: 500 mm. Different lengths must be specified placing the order.

⁽²⁾ Standard length of the remote tubings: 1000 mm. Different lengths must be specified placing the order.

Unless different instructions placing the order : the control and the regulation valves will be assembled reducing the dimension of the unit.

UI...

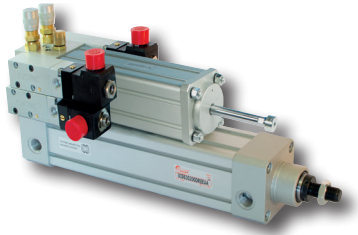

2

PNEUMO-HYDRAULIC ACTUATORS

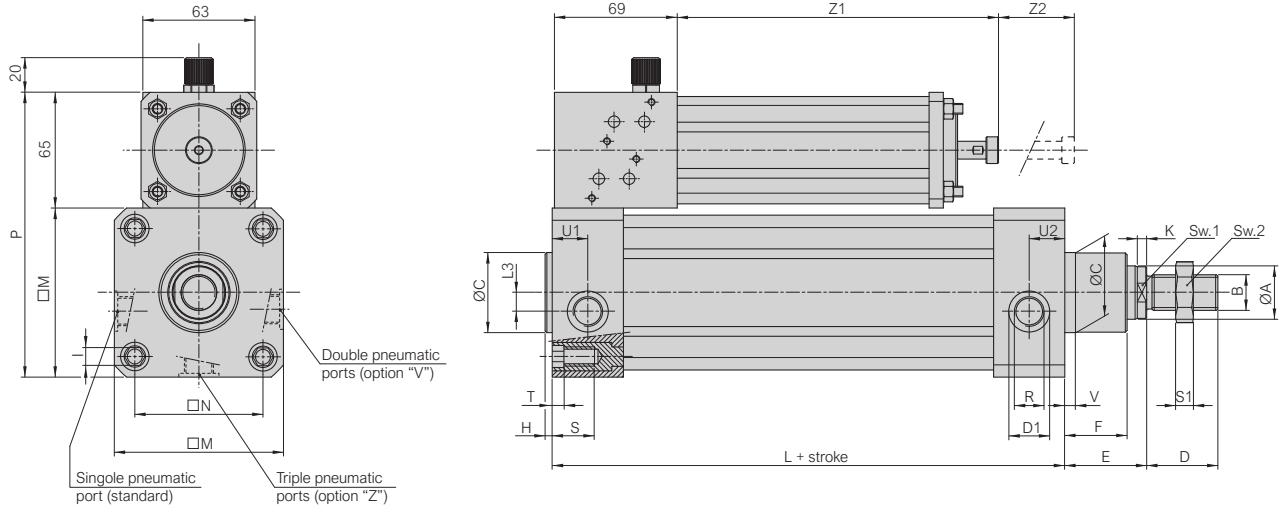

Bore	Ø A	B	Ø C	D	D1	E	F	H	I	K	L+	L3	M	N	P	R	S	S1	SW1	SW2	T	U1	U2	V			
mm	f7		d11	⁰ / ₋₂													Min	Ch	Ch								
50	25	M16 x 1,5	40	32	19	37	±1,4	26	4	M8	5	106	±0,7	8	65	46,5	±0,6	130	Gas 1/4"	20	8	23	23	5,5	26	20	10
63	30	M16 x 1,5	45	32	23	37		26	4	M8	5	121	±0,8	11	75	56,5		140	Gas 3/8"	22	8	27	23	8	22	23	4
80	30	M20 x 1,5	45	40	23	46	±1,8	35	4	M10	5	128	±0,8	0	95	72	±0,7	160	Gas 3/8"	20	10	27	26	6	20	20	6
100	40	M20 x 1,5	55	40	27	51		38	4	M10	6	138	±1	0	110	89		175	Gas 1/2"	23	10	36	28	9	21,5	21,5	5
125	45	M27 x 2	60	54	27	65	±2,2	50	6	M12	6	160	±1	0	140	110	±1,1	205	Gas 1/2"	28	13,5	41	41	10	25	25	8
Bore	Z1	Z2	Z1	Z2	Z1	Z2	Z1	Z2	Z1	Z2	Z1	Z2	Z1	Z2	Z1	Z2											
mm	Stroke 50 ÷ 170		Stroke 171 ÷ 630		Stroke 631 ÷ 885		Stroke 886 ÷ 1100																				
50	130	10	170	38	210	53	232	63																			
Bore	Z1	Z2	Z1	Z2	Z1	Z2	Z1	Z2	Z1	Z2	Z1	Z2	Z1	Z2													
mm	Stroke 50 ÷ 170		Stroke 171 ÷ 330		Stroke 331 ÷ 480		Stroke 481 ÷ 575		Stroke 576 ÷ 675		Stroke 676 ÷ 850		Stroke 851 ÷ 1180														
63 ÷ 125	130	10	170	38	210	53	232	63	278	80	375	120	575	168													

UT...

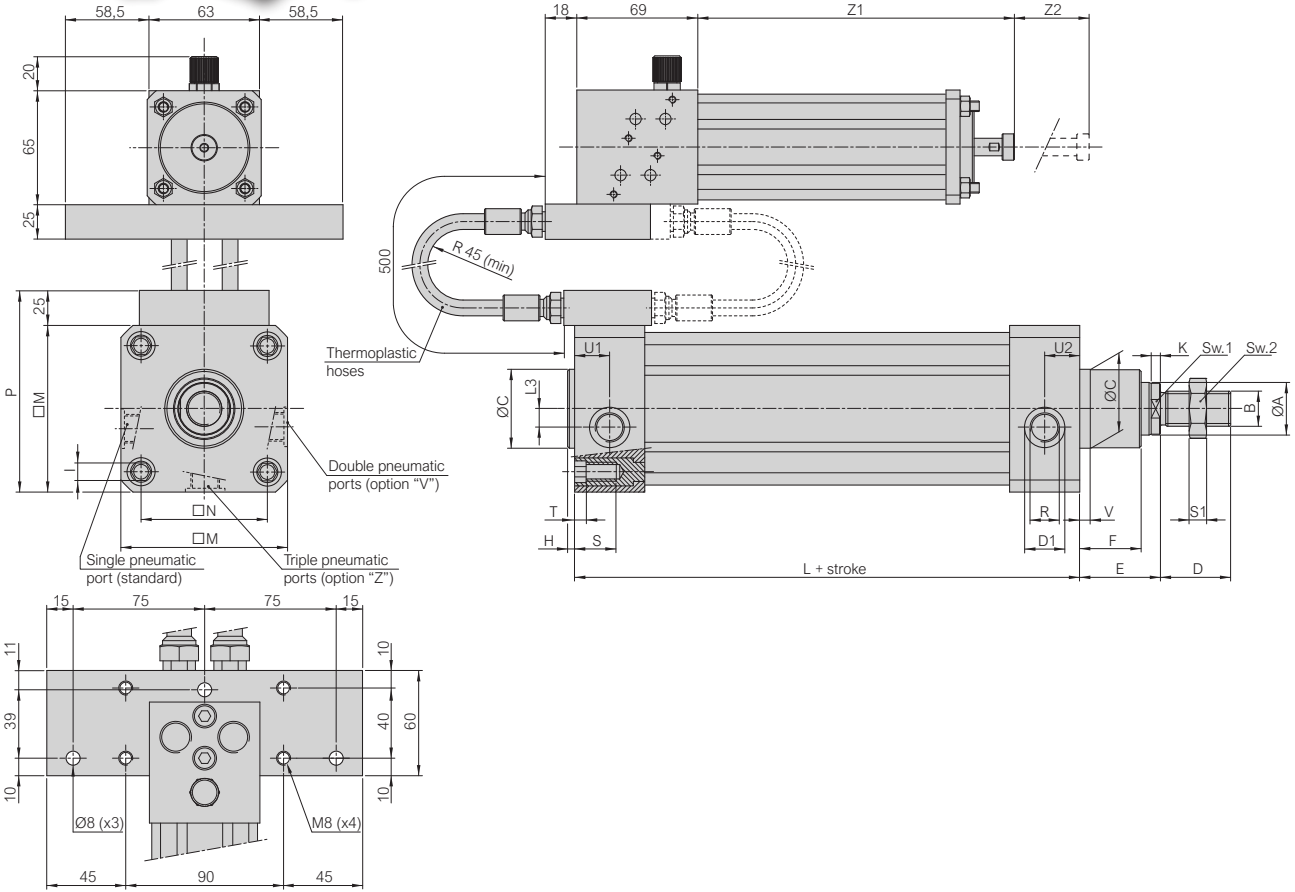
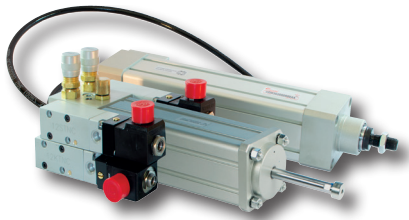

Bore	Ø A	B	Ø C	D	D1	E	F	H	I	K	L+	L3	M	N	P	R	S	S1	SW1	SW2	T	U1	U2	V			
mm	f7		d11	⁰ / ₋₂													Min	Ch	Ch								
50	25	M16 x 1,5	40	32	19	37	±1,4	26	4	M8	5	106	±0,7	8	65	46,5	±0,6	85	Gas 1/4"	20	8	23	23	5,5	26	20	10
63	30	M16 x 1,5	45	32	23	37		26	4	M8	5	121	±0,8	11	75	56,5		95	Gas 3/8"	22	8	27	23	8	22	23	4
80	30	M20 x 1,5	45	40	23	46	±1,8	35	4	M10	5	128		0	95	72	±0,7	115	Gas 3/8"	20	10	27	26	6	20	20	6
100	40	M20 x 1,5	55	40	27	51		38	4	M10	6	138		0	110	89		130	Gas 1/2"	23	10	36	28	9	21,5	21,5	5
125	45	M27 x 2	60	54	27	65	±2,2	50	6	M12	6	160	±1	0	140	110	±1,1	160	Gas 1/2"	28	13,5	41	41	10	25	25	8

Bore	Z1	Z2	Z1	Z2	Z1	Z2	Z1	Z2
mm	Stroke 50 ÷ 170		Stroke 171 ÷ 630		Stroke 631 ÷ 885		Stroke 886 ÷ 1100	
50	130	10	170	38	210	53	232	63

Bore	Z1	Z2	Z1	Z2	Z1	Z2	Z1	Z2						
mm	Stroke 50 ÷ 170		Stroke 171 ÷ 330		Stroke 331 ÷ 480		Stroke 481 ÷ 575		Stroke 576 ÷ 675		Stroke 676 ÷ 850		Stroke 851 ÷ 1180	
63 ÷ 125	130	10	170	38	210	53	232	63	278	80	375	120	575	168

THERMOPLASTIC HOSE

Flexible thermoplastic hose for high pressure hydraulic applications SAE 100 R7 - Standard length = 500mm (x2) - Different lengths must be specified placing the order.

UB...

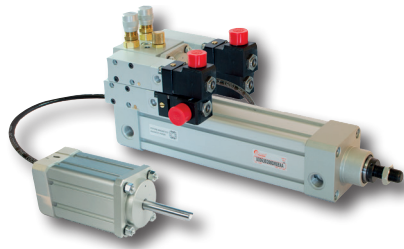

2

PNEUMO-HYDRAULIC ACTUATORS

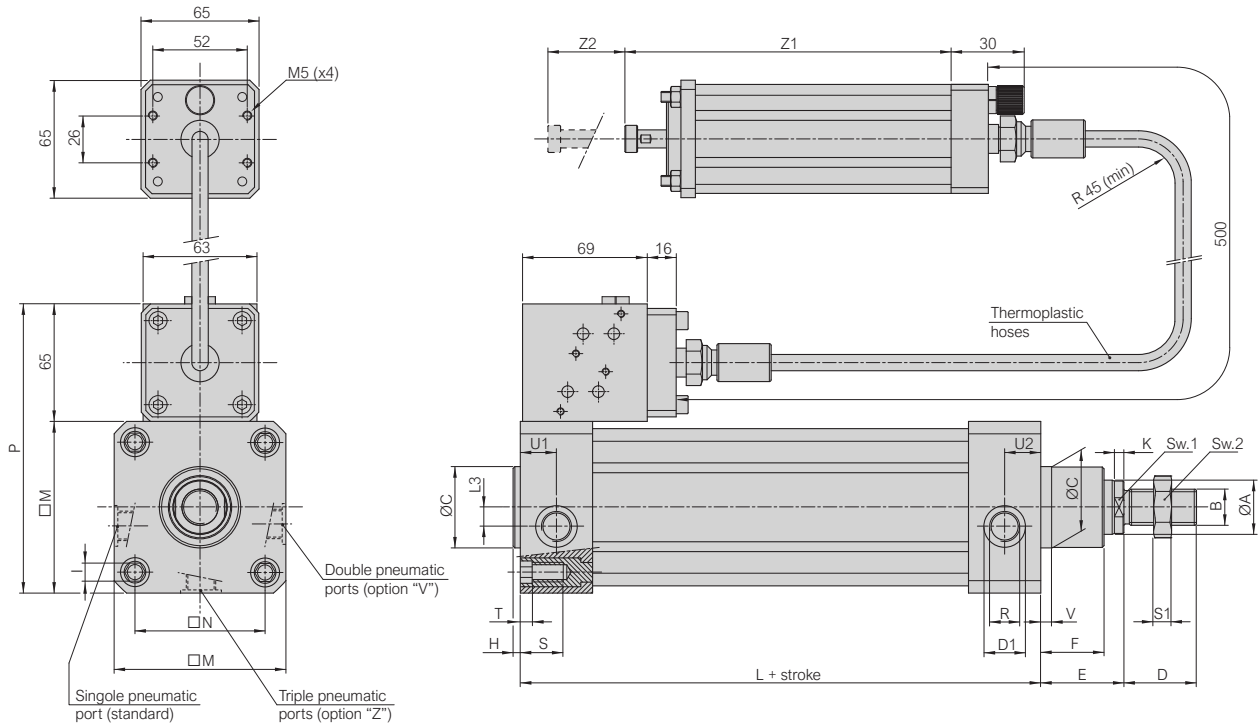

Bore	ØA	B	ØC	D	D1	E	F	H	I	K	L+	L3	M	N	P	R	S	S1	SW1	SW2	T	U1	U2	V			
mm	f7		d11	⁰ / ₋₂													Min	Ch	Ch								
50	25	M16 x 1,5	40	32	19	37	±1,4	26	4	M8	5	106	±0,7	8	65	46,5	±0,6	85	Gas 1/4"	20	8	23	23	5,5	26	20	10
63	30	M16 x 1,5	45	32	23	37		26	4	M8	5	121	±0,8	11	75	56,5		95	Gas 3/8"	22	8	27	23	8	22	23	4
80	30	M20 x 1,5	45	40	23	46	±1,8	35	4	M10	5	128		0	95	72	±0,7	115	Gas 3/8"	20	10	27	26	6	20	20	6
100	40	M20 x 1,5	55	40	27	51		38	4	M10	6	138		0	110	89		130	Gas 1/2"	23	10	36	28	9	21,5	21,5	5
125	45	M27 x 2	60	54	27	65	±2,2	50	6	M12	6	160	±1	0	140	110	±1,1	160	Gas 1/2"	28	13,5	41	41	10	25	25	8

Bore	Z1	Z2	Z1	Z2	Z1	Z2	Z1	Z2
mm	Stroke 50 ÷ 170		Stroke 171 ÷ 630		Stroke 631 ÷ 885		Stroke 886 ÷ 1100	
50	130	10	170	38	210	53	232	63

Bore	Z1	Z2	Z1	Z2	Z1	Z2	Z1	Z2						
mm	Stroke 50 ÷ 170		Stroke 171 ÷ 330		Stroke 331 ÷ 480		Stroke 481 ÷ 575		Stroke 576 ÷ 675		Stroke 676 ÷ 850		Stroke 851 ÷ 1180	
63 ÷ 125	130	10	170	38	210	53	232	63	278	80	375	120	575	168

THERMOPLASTIC HOSE

Flexible thermoplastic hose for high pressure hydraulic applications SAE 100 R7 - Standard length = 500mm (x1) - Different lengths must be specified placing the order.

SPEED REGULATORS

Speed regulators on manifold group standard / precise / small size

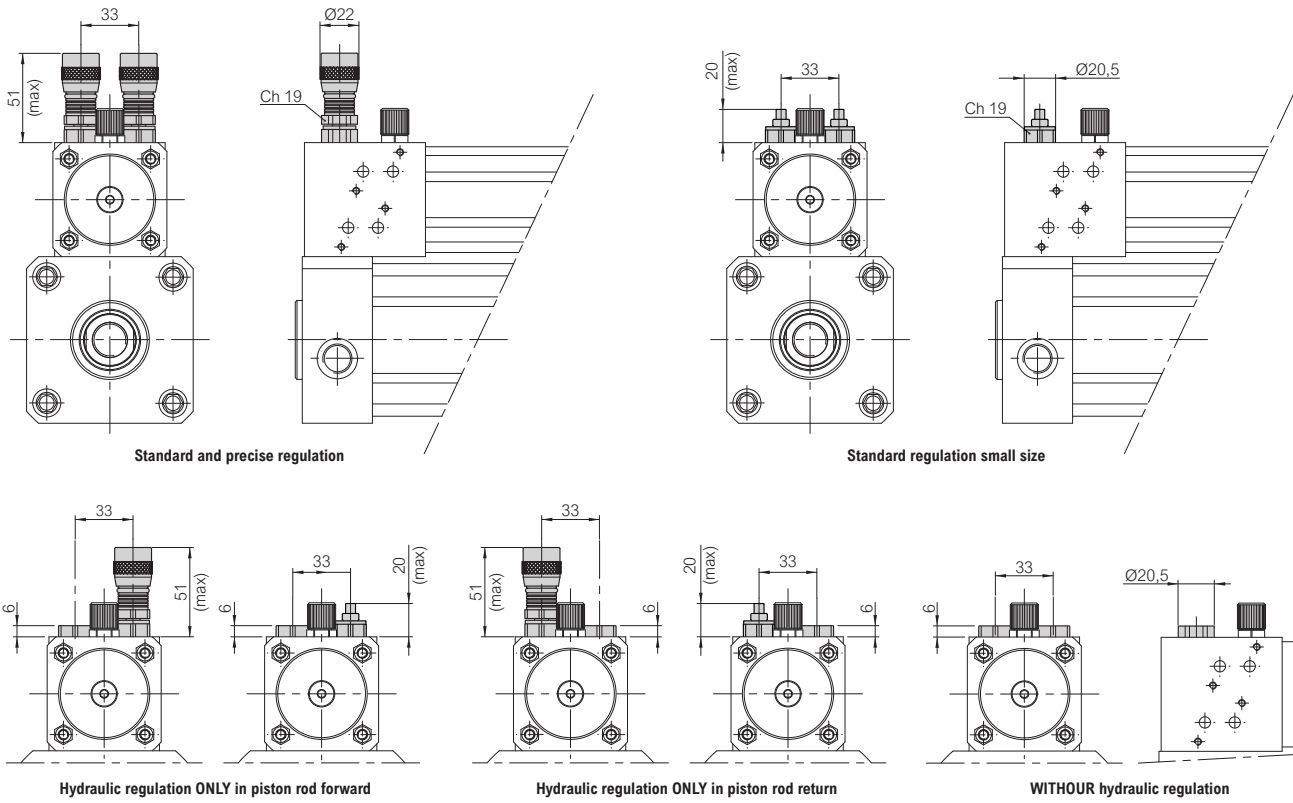

Speed regulators remoted standard / precise / small size

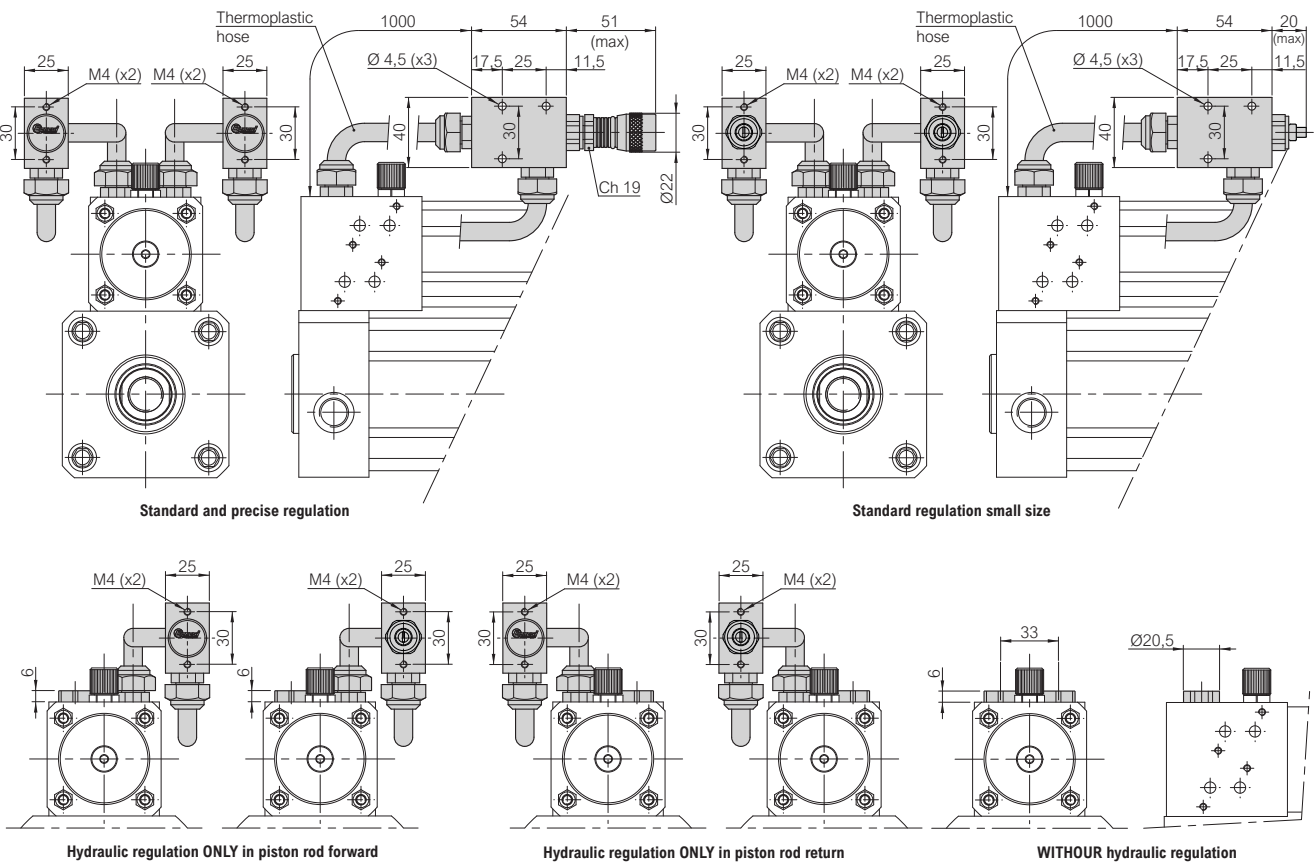

THERMOPLASTIC HOSE

Flexible thermoplastic hose for high pressure hydraulic applications SAE 100 R7 - Standard lenght = 1000mm - Different lenghts must be specified placing the order.

STOP CONTROL VALVES

STOP control valves solenoid actuated

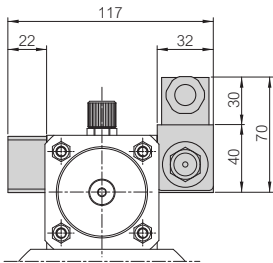
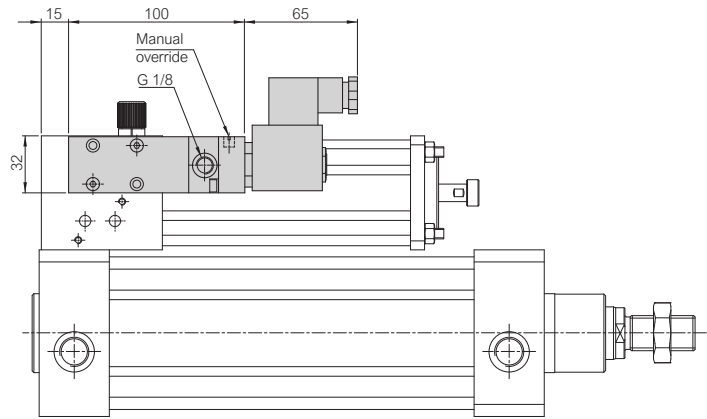
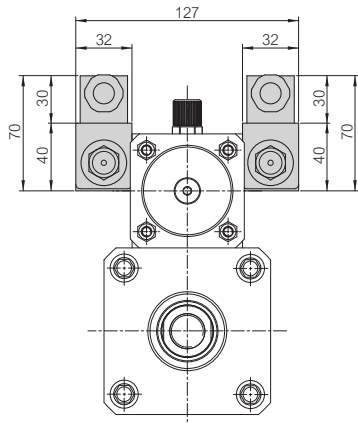

Control valve ONLY in piston rod forward

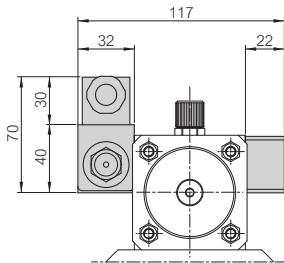

Control valve ONLY in piston rod return

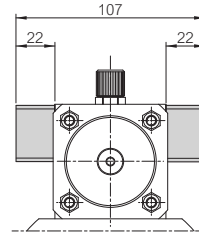

WITHOUT Control valve

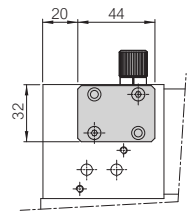

STOP control valves pneumatic actuated

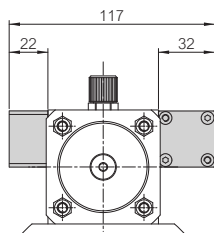
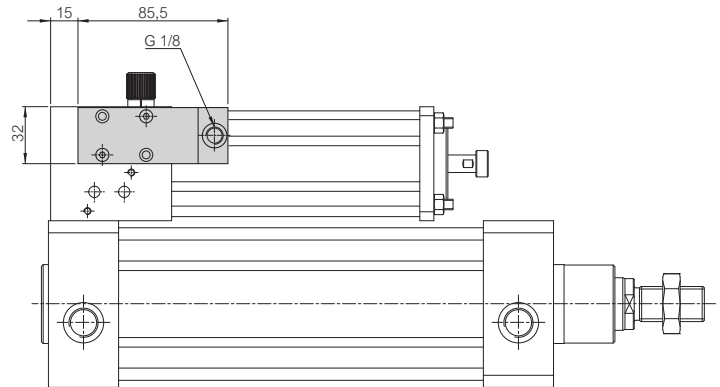
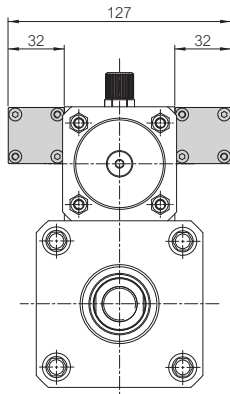

Control valve ONLY in piston rod forward

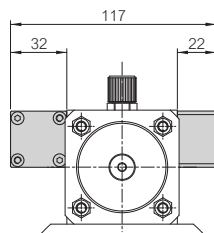

Control valve ONLY in piston rod return

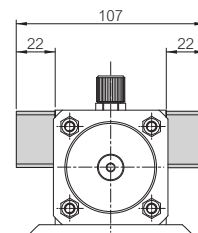

WITHOUT Control valve

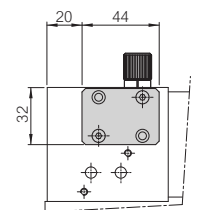

Unless different instructions placing the order : the control and the regulation valves will be assembled reducing the dimension of the unit.

STOP CONTROL VALVES

STOP control valves solenoid actuated with speed adjustment (in agreement with the Commercial Department)

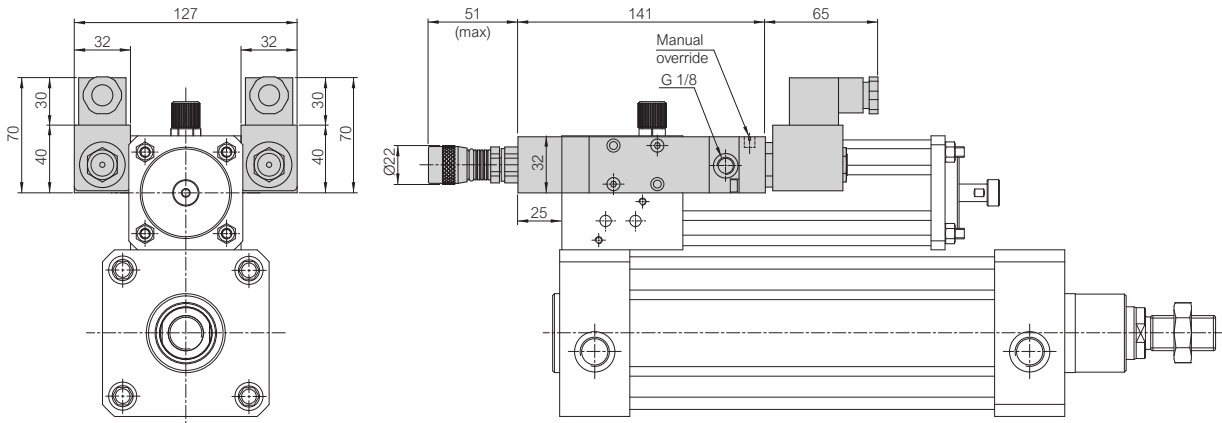

Control valve ONLY in piston rod forward

Control valve ONLY in piston rod return

WITHOUT Control valve

2
PNEUMO-HYDRAULIC ACTUATORS

STOP control valves pneumatic actuated with speed adjustment (in agreement with the Commercial Department)

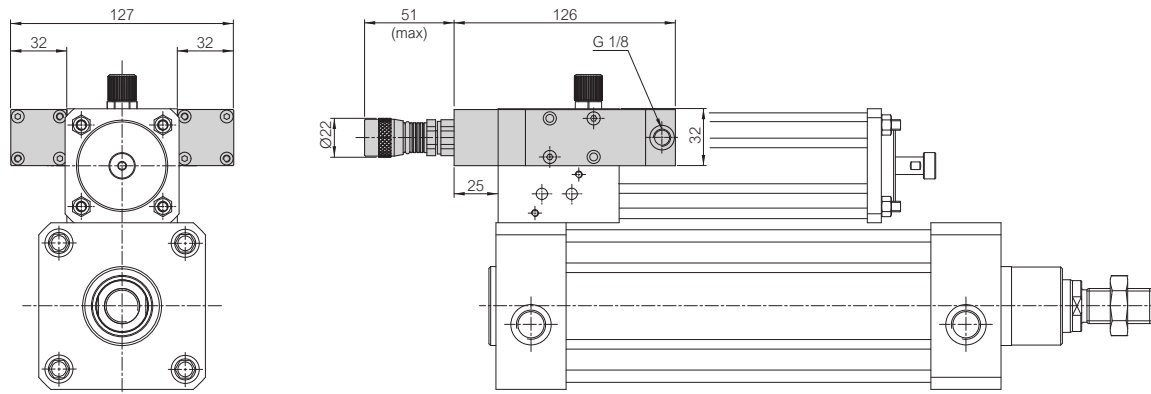

Control valve ONLY in piston rod forward

Control valve ONLY in piston rod return

WITHOUT Control valve

Unless different instructions placing the order : the control and the regulation valves will be assembled reducing the dimension of the unit.

STOP CONTROL VALVES

STOP control valves solenoid actuated with remoted speed adjustment (in agreement with the Commercial Department)

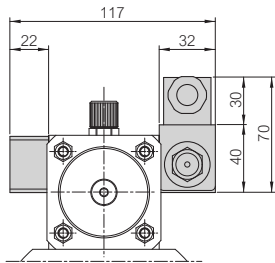
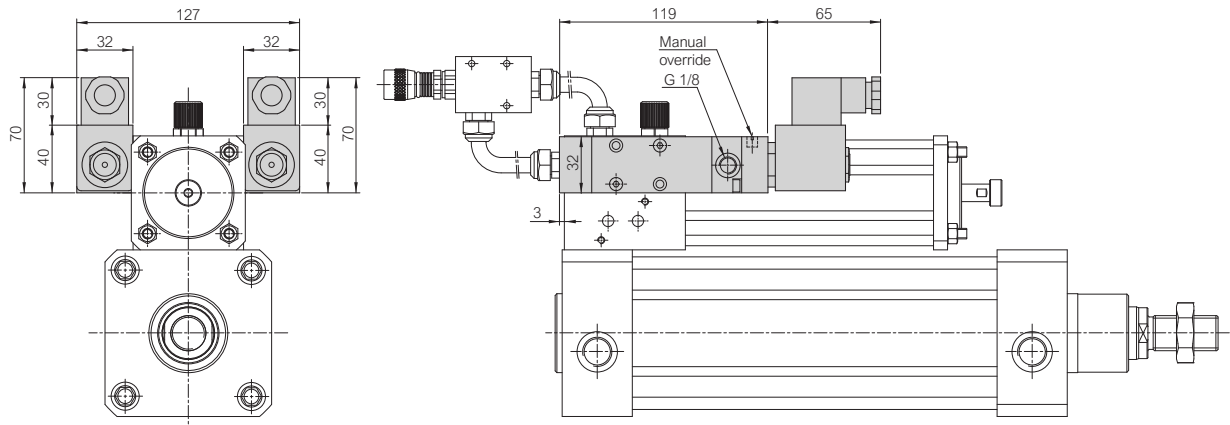

Control valve ONLY in piston rod forward

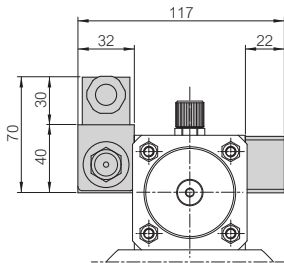

Control valve ONLY in piston rod return

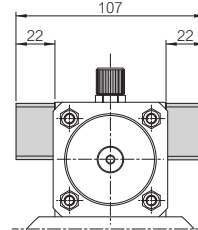

WITHOUT Control valve

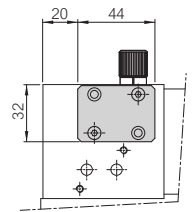

STOP control valves pneumatic actuated with remoted speed adjustment (in agreement with the Commercial Department)

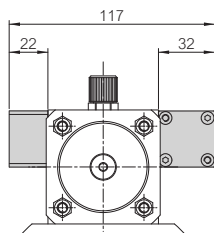
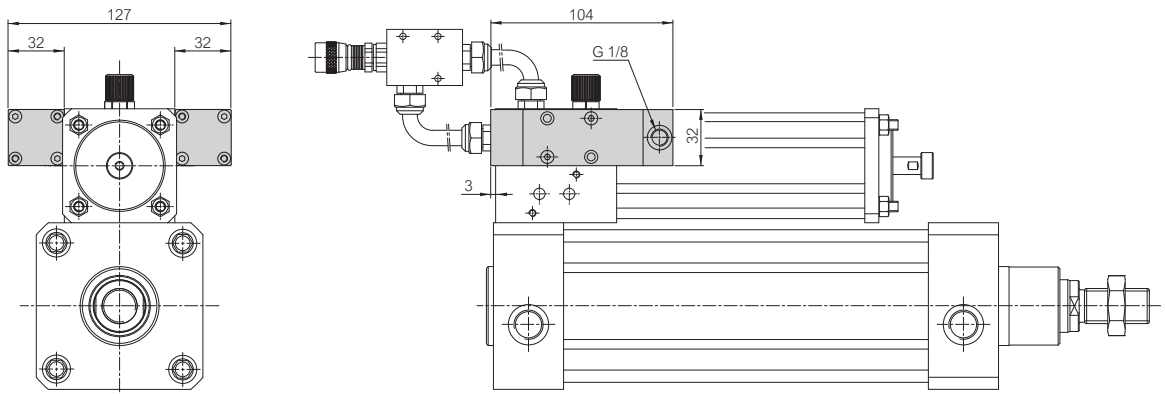

Control valve ONLY in piston rod forward

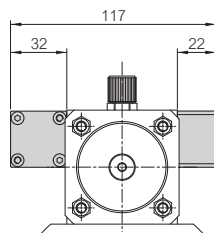

Control valve ONLY in piston rod return

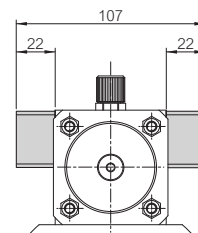

WITHOUT Control valve

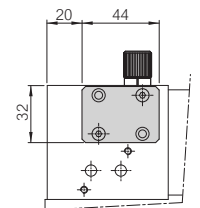

Unless different instructions placing the order : the control and the regulation valves will be assembled reducing the dimension of the unit.

SKIP CONTROL VALVES

SKIP control valves solenoid actuated

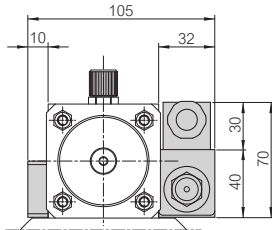
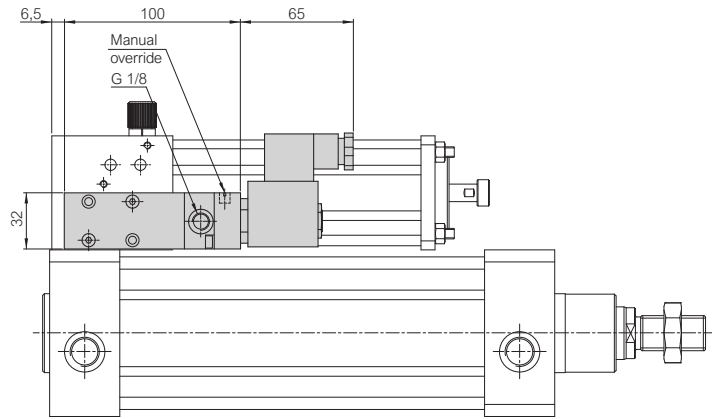
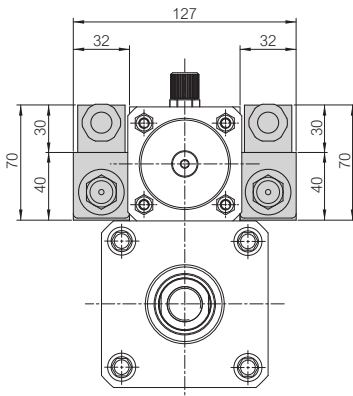

Control valve ONLY in piston rod forward

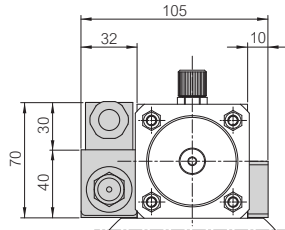

Control valve ONLY in piston rod return

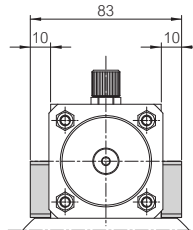

WITHOUT Control valve

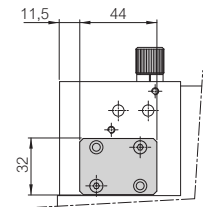

SKIP control valves pneumatic actuated

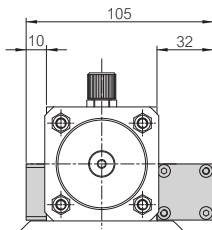
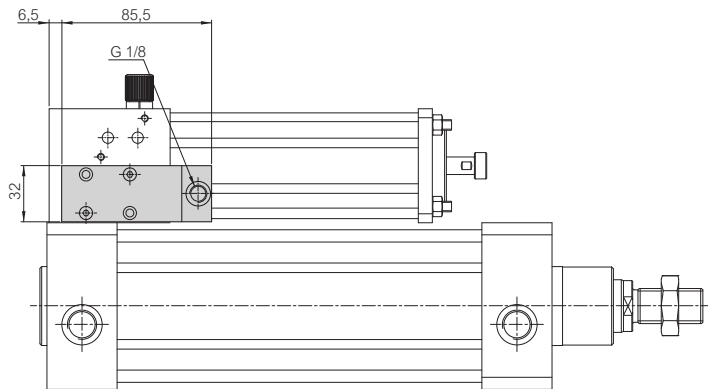
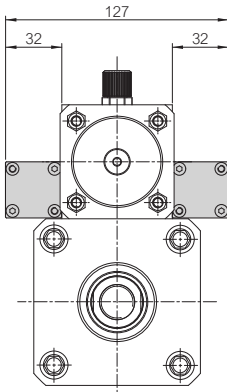

Control valve ONLY in piston rod forward

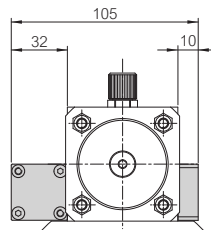

Control valve ONLY in piston rod return

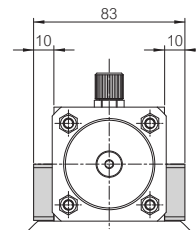

WITHOUT Control valve

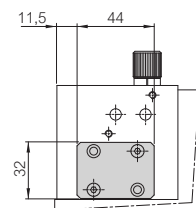

Unless different instructions placing the order : the control and the regulation valves will be assembled reducing the dimension of the unit.

SKIP CONTROL VALVES

SKIP control valves solenoid actuated with speed adjustment (in agreement with the Commercial Department)

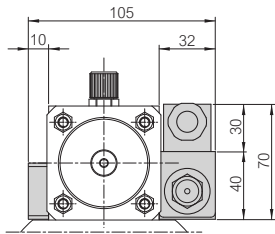
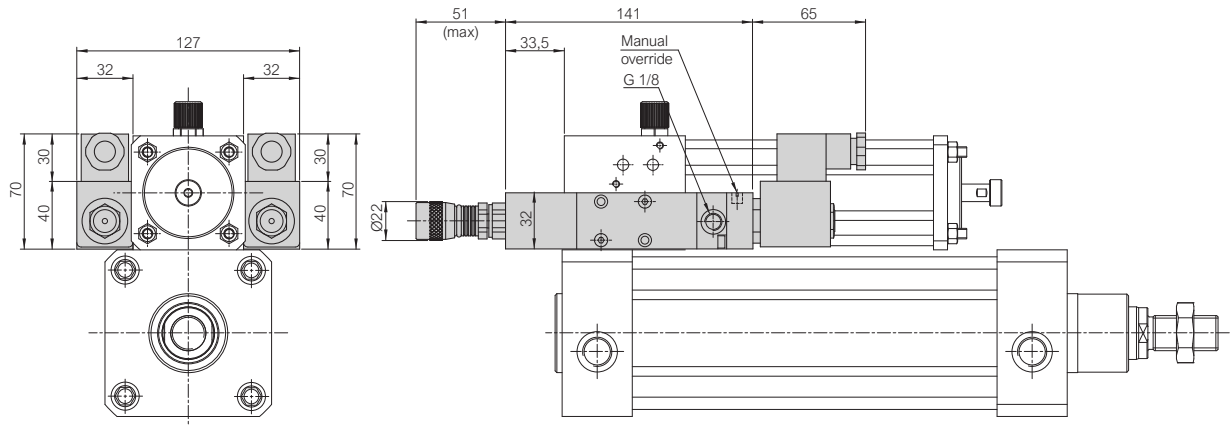

Control valve ONLY in piston rod forward

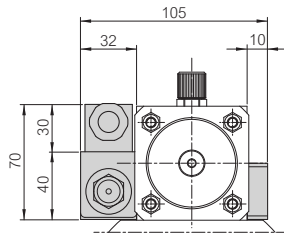

Control valve ONLY in piston rod return

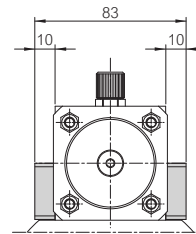

WITHOUT Control valve

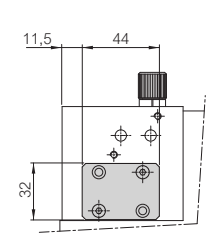

SKIP control valves pneumatic actuated with speed adjustment (in agreement with the Commercial Department)

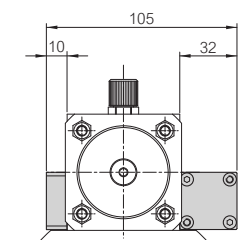
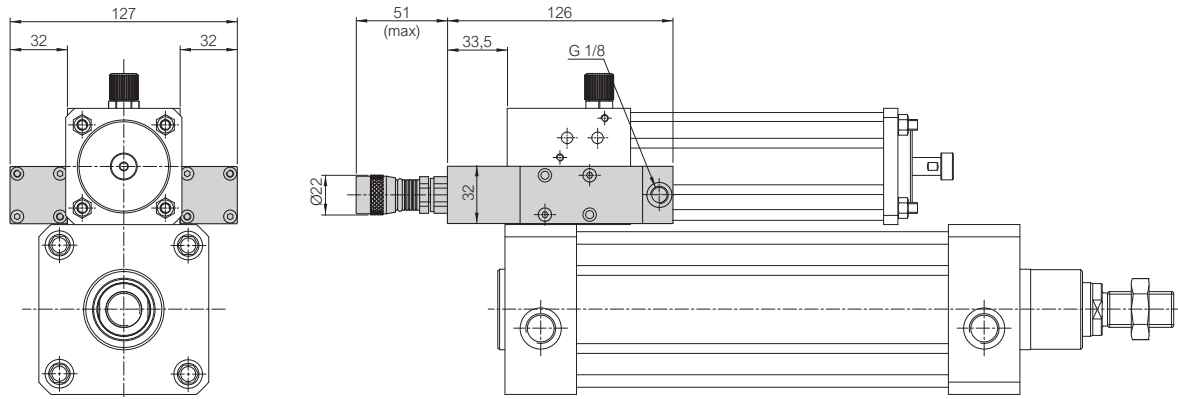

Control valve ONLY in piston rod forward

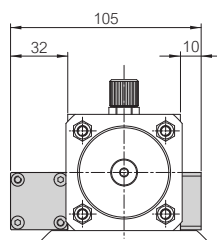

Control valve ONLY in piston rod return

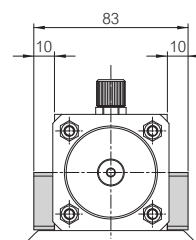

WITHOUT Control valve

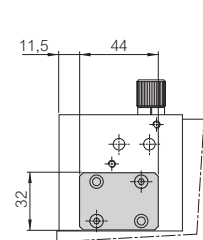

Unless different instructions placing the order : the control and the regulation valves will be assembled reducing the dimension of the unit.

SKIP CONTROL VALVES

SKIP control valves solenoid actuated with remoted speed adjustment (in agreement with the Commercial Department)

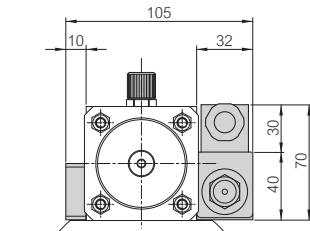
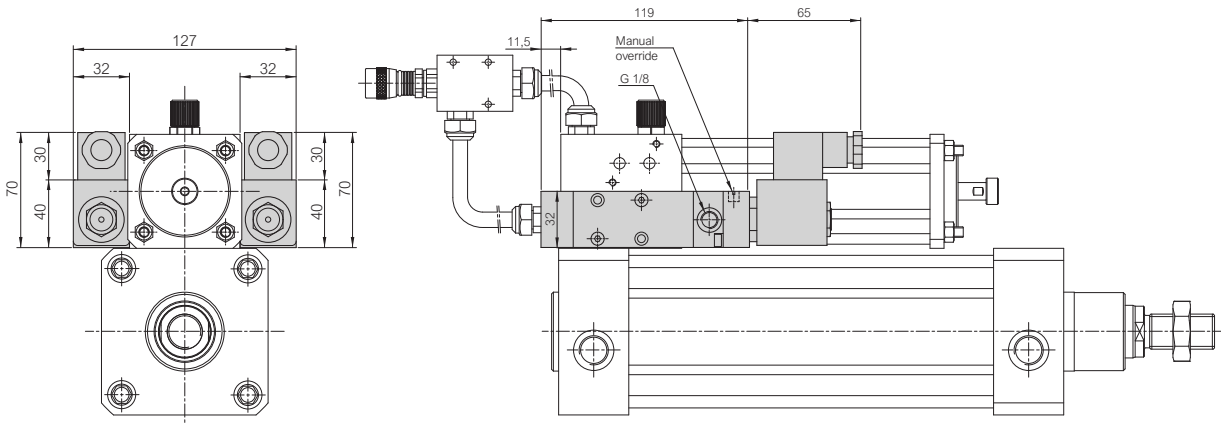

Control valve ONLY in piston rod forward

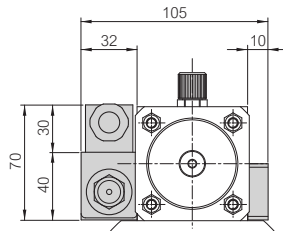

Control valve ONLY in piston rod return

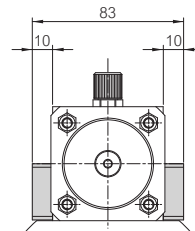

WITHOUT Control valve

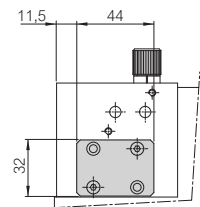

SKIP control valves pneumatic actuated with remoted speed adjustment (in agreement with the Commercial Department)

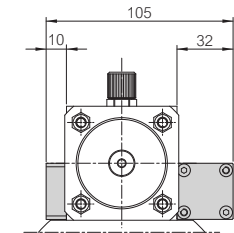
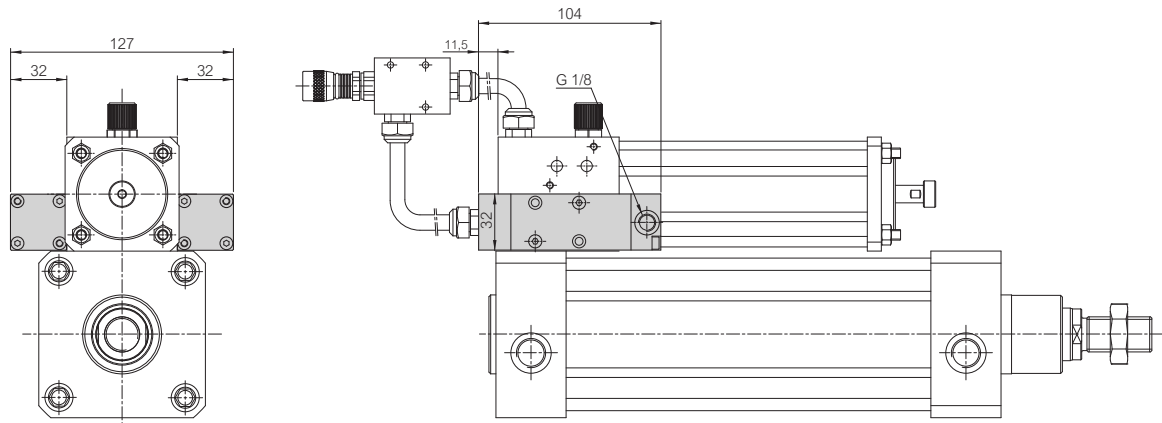

Control valve ONLY in piston rod forward

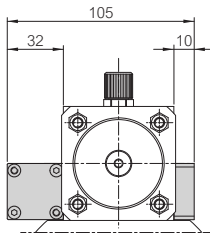

Control valve ONLY in piston rod return

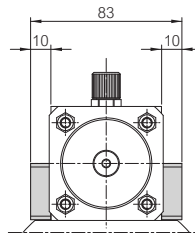



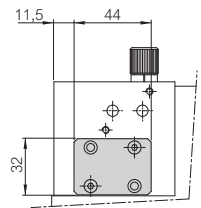









WITHOUT Control valve



Unless different instructions placing the order : the control and the regulation valves will be assembled reducing the dimension of the unit.



ACCESSORIES			
UI SEC ... Pin for female hinge MP2 (AA4)	UI SECH ... Pin for female hinge MP6 (AA6)	MRP200 Manual oil refill pump	SUPERMATIC46 Fluid for hydraulic circuit
			
Ø Page 2.1.05.24	Page 2.1.05.24	Page 2.1.05.24	
50 UI SEC 050	UI SECH 050		UI SG 050
63 UI SEC 063	UI SECH 063		UI SG 063
80 UI SEC 080	UI SECH 080		UI SG 080
100 UI SEC 100	UI SECH 100		UI SG 100
125 UI SEC 125	UI SECH 125		UI SG 125
White zinc coating steel	White zinc coating steel	Pump: ABS, steel Adapter: Brass Pipe: Rilsan	Oil DEXRON II Package: 1 lt Rod seals: Polyurethane Other seals: NBR
SR ... NC sensors REED / HALL	SK9 ... IP69K sensor PNP	SKC ... Precise position sensor PNP	Y082LC / Y083LC Straight connectors
			
Page 2.1.05.25	Page 2.1.05.26	Page 2.1.05.26	Page 2.1.05.27
Sensor: PA6 Cable: PUR	Sensor: PA12 Cable: PUR	Sensor: PA Cable: PUR	Connector: PVC Contacts: Gilded brass Cable: PVC
Y45EG3 ... Coils in direct current	Y45EG3 ... Coils in alternate current	CNN2 ... Connectors for coils	CNN2 ... LED Connectors for coils
			
Page 2.1.05.28	Page 2.1.05.28	Page 2.1.05.28	Page 2.1.05.28
Encapsulated PA 6.6 + GLASS FIBER	Encapsulated PA 6.6 + GLASS FIBER	PA6 GF	PA6 GF - PA12

PISTON ROD ACCESSORIES

UI IFF ... Female clevis	Bore mm	Code	AA	AB	Ø AC h11	AD $\begin{matrix} +0,30 \\ -0,16 \end{matrix}$	AE ±0,5	AF ±0,5	AG ±0,4	AH ±0,2	AL
	50	UI IFF 050	16	M16 x 1,5	16	32	32	83	64	36	6
	63	UI IFF 063	16	M16 x 1,5	16	32	32	83	64	36	6
	80	UI IFF 080	20	M20 x 1,5	20	40	40	105	80	44	5
	100	UI IFF 100	20		20	40	40	105	80	44	5
	125	UI IFF 125	30	M27 x 2	30	55	54	148	110	65	-

UI IFF ... Clevis and clip in galvanized steel / 1 piece each package

UI IKJ ... Self-lubricating oscillating joint	Alesaggio mm	Codice	AB	Ø AC H7	AM	AN Ch	AO	AP	AQ	Ø AR	Ø AS	Ø AT	AU	AV	AZ
	50	UI IKJ 050	M16 x 1,5	16	28	22	42	21	15	19,3	22	27	8	64	85
	63	UI IKJ 063	M16 x 1,5	16	28	22	42	21	15	19,3	22	27	8	64	85
	80	UI IKJ 080	M20 x 1,5	20	33	30	50	25	18	24,3	27,5	34	10	77	102
	100	UI IKJ 100	M20 x 1,5	20	33	30	50	25	18	24,3	27,5	34	10	77	102
	125	UI IKJ 125	M27 x 2	30	51	41	70	37	25	34,8	40	50	15	110	145

UI IKJ ... Joint in galvanized steel, bush in sintered bronze, ring in hardened bearing steel / 1 piece each package

UI IKK ... Self-aligning joint angular and radial	Bore mm	Code	A	B	C	D	E	Ø F	Ø G	Ø H	L	M	Ch1	Ch2	Ch3	β	Static load daN
	50	UI IKK 050	M16 x 1,5	104	32	10	53	22	32	45	2	30	20	27	41	6	1000
	63	UI IKK 063	M16 x 1,5	104	32	10	53	22	32	45	2	30	20	27	41	6	1000
	80	UI IKK 080	M20 x 1,5	119	40	10	53	22	32	45	2	37	20	27	41	6	1000
	100	UI IKK 100	M20 x 1,5	119	40	10	53	22	32	45	2	37	20	27	41	6	1000
	125	UI IKK 125	M27 x 2	147	54	10	60	32	57	70	2	48	24	54	65	8	3000

UI IKK ... Joint and nut in galvanized steel steel, pin in burnished steel / 1 piece each package

UI DS ... Rod nut	Bore mm	Code	B	S1	Sw.2 Ch
	50	UI DS 050	M16 x 1,5	8	23
	63	UI DS 063	M16 x 1,5	8	23
	80	UI DS080	M20 x 1,5	10	26
	100	UI DS100	M20 x 1,5	10	28
	125	UI DS125	M27 x 2	13,5	41

UI DS ...Rod nut in galvanized steel / 1 piece each package

MOUNTING ACCESSORIES

UI 2801 ... / UI 2901 ...
Female hinge (MP2)

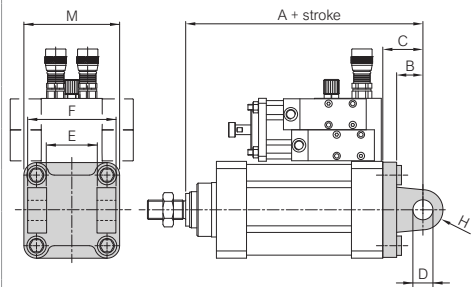

Bore mm	Code	A+	B	C	D	E	F	M	H	Fixing screw
50	UI 2801 050 UI 2901 050	170 ±1,25	16	27 ±0,2	12 H9	32 H14	60 h14	65	12	M8 x 25
63	UI 2801 063 UI 2901 063	190	21	32	16	40	70	75	16	M8 x 25
80	UI 2801 080 UI 2901 080	210 ±1,6	22	36	16	50	90	95	16	M10 x 30
100	UI 2801 100 UI 2901 100	230	27	41	20	60	110	115	20	M10 x 30
125	UI 2801 125 UI 2901 125	275 ±2	30	50	25	70	130	140	25	M12 x 35

UI 2801 ... Light alloy / UI 2901 ... Painted steel black cataphoresis / 1 piece each package + 4 screws for fixing to cylinder

UI 2802 ... / UI 2902 ...
Male hinge (MP4)

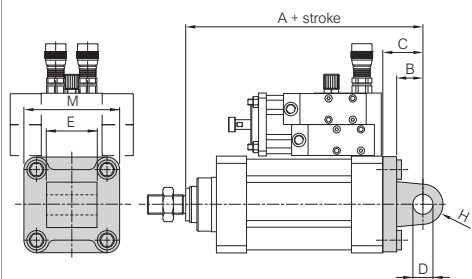

Bore mm	Code	A+	B	C	D	E	M	H	Fixing screw
50	UI 2802 050 UI 2902 050	170 ±1,25	16	27 ±0,2	12 H9	32	65	12	M8 x 25
63	UI 2802 063 UI 2902 063	190	21	32	16	40	75	16	M8 x 25
80	UI 2802 080 UI 2902 080	210 ±1,6	22	36	16	50	95	16	M10 x 30
100	UI 2802 100 UI 2902 100	230	27	41	20	60	115	20	M10 x 30
125	UI 2802 125 UI 2902 125	275 ±2	30	50	25	70	140	25	M12 x 35

UI 2802 ... Light alloy / UI 2902 ... Painted steel black cataphoresis / 1 piece each package + 4 screws for fixing to cylinder

UI 2803 ... / UI 2903 ...
Square joint at 90° (AB7)

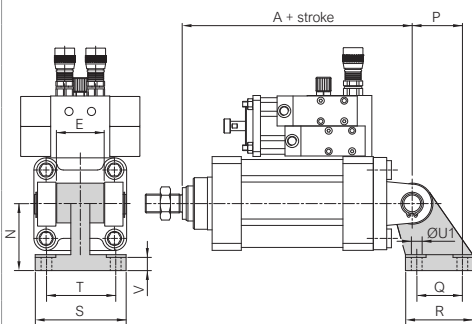

Bore mm	Code	A+	E	N	P	Q	R	S	T	ØU1	V
50	UI 2803 050 UI 2903 050	170 ±1,25	32	45 JS15	33 JS14	30 JS14	45	65	50	9	10,4
63	UI 2803 063 UI 2903 063	190	40	50	37	35	50	67	52	9	12,4
80	UI 2803 080 UI 2903 080	210 ±1,6	50	63	47	40	60	86	66	11	11,5
100	UI 2803 100 UI 2903 100	230	60	71	55	50	70	96	76	11	14,5
125	UI 2803 125 UI 2903 125	275 ±2	70	90	70	60	90	124	94	14	16,8

UI 2803 ... Light alloy / UI 2903 ... Painted steel black cataphoresis / 1 piece each package

UI 2804 ... / UI 2904 ...
Narrow female hinge (AB6) with pin UI SECH ...

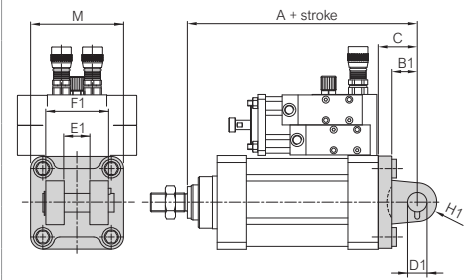

Bore mm	Code	A+	B1	C	D1	E1	F1	H1	M	Fixing screw
50	UI 2804 050 UI 2904 050	170 ±1,25	16	27 ±0,2	16 f7	21 H14	45 d12	14	65	M8 x 20
63	UI 2804 063 UI 2904 063	190	21	32	16	21	51	18	75	M8 x 20
80	UI 2804 080 UI 2904 080	210 ±1,6	22	36	20	25	65	20	95	M10 x 25
100	UI 2804 100 UI 2904 100	230	27	41	20	25	75	22	115	M10 x 25
125	UI 2804 125 UI 2904 125	275 ±2	30	50	30	37	97	25	140	M12 x 35

UI 2804 ... Light alloy / UI 2904 ... Painted steel black cataphoresis - PIN in white zinc plated steel / 1 piece each package + 4 screws for fixing to cylinder

MOUNTING ACCESSORIES

UI 2805 ... / UI 2905 ... Narrow male hinge with articulated head (MP6)		Bore	Code	A+	AQ	B1	C	D1	E1	M	H2	Fixing screw
		mm					±0,2	H7	±0,2			ISO 4762
	50	UI 2805 050 UI 2905 050	170	±1,25	15	16	27	16	21	65	21	M8 x 20
	63	UI 2805 063 UI 2905 063	190		15	21	32	16	21	75	24	M8 x 20
	80	UI 2805 080 UI 2905 080	210	±1,6	18	22	36	20	25	95	28,5	M10 x 25
	100	UI 2805 100 UI 2905 100	230		18	27	41	20	25	115	30	M10 x 25
	125	UI 2805 125 UI 2905 125	275	±2	25	30	50	30	37	140	40	M12 x 35
UI 2805 ... Light alloy / UI 2905 ... Painted steel black cataphoresis / 1 piece each package + 4 screws for fixing to cylinder												

UI 2806 ... / UI 2906 ... Square joint at 90° with articulated head		Bore	Code	A+	AQ	E1	N	P	Q	R	S	T	ØU	V
		mm				$\begin{smallmatrix} 0 \\ -0,1 \end{smallmatrix}$	JS15	JS15	JS14			JS14	H13	$\begin{smallmatrix} +0,5 \\ 0 \end{smallmatrix}$
	50	UI 2806 050 UI 2906 050	170	±1,25	15	21	45	33	30	45	65	50	9	10,5
	63	UI 2806 063 UI 2906 063	190		15	21	50	37	35	50	67	52	9	10,5
	80	UI 2806 080 UI 2906 080	210	±1,6	18	25	63	47	40	60	86	66	11	11,5
	100	UI 2806 100 UI 2906 100	230		18	25	71	55	50	70	96	76	11	12,5
	125	UI 2806 125 UI 2906 125	275	±2	25	37	90	70	60	90	124	94	13,5	17
UI 2806 ... Light alloy / UI 2906 ... Painted steel black cataphoresis / 1 piece each package														

UI 2907 ... Front and rear flange ISO (MF1-MF2)		Bore	Code	A1+	B2	C1	D2	E2	F2	G	M	Fixing screw	
		mm			±0,2		JS14	JS14	H13			ISO 4762	
	50	UI 2907 050	155	±1,25	12	110	90	45	9	25	±1,6	65	M8 x 20
	63	UI 2907 063	170		12	120	100	50	9	25		75	M8 x 20
	80	UI 2907 080	190	±1,6	16	150	126	63	12	30	±2	95	M10 x 20
	100	UI 2907 100	205		16	170	150	75	14	35		115	M10 x 20
	125	UI 2907 125	245	±2	20	205	180	90	16	45	±2,5	140	M12 x 30
UI 2907 ... White zinc plated steel / 1 piece each package + 4 screws for fixing to cylinder													

UI 2908 ... Low foot pedestal (MS1)		Bore	Code	A2+	B3	C2	E2	ØG1	M	N	Q1+	Q2	V1	Fixing screw		
		mm			±0,2			JS14	H14	JS16			±0,5	ISO 4762		
	50	UI 2908 050	175	±1,25	32	47	45	9	65	45	170	±1,6	5	±0,35	5	M8 x 20
	63	UI 2908 063	190		32	45	50	9	75	50	185		5		5	M8 x 20
	80	UI 2908 080	215	±1,6	41	55	63	12	95	63	210	±2	5	±0,4	6	M10 x 25
	100	UI 2908 100	230		41	57	75	14	115	71	220		10		6	M10 x 25
	125	UI 2908 125	270	±2	45	70	90	16	140	90	250	±2,5	20	±0,5	8	M12 x 35
UI 2908 ... White zinc plated steel / 1 piece each package + 2 screws for fixing to cylinder																

MOUNTING ACCESSORIES

UI 2909 ... TQ (series UI) Adjustable intermediate hinge (MT4)	Bore mm	Code	A3 h14	B4 h14	C3	Ø D3 e9	E3	Xmin
	50	UI 2909 050 TQ	75	16	71	16	20	81
	63	UI 2909 063 TQ	90	20	84	20	26	89
	80	UI 2909 080 TQ	110	20	105	20	26	99
	100	UI 2909 100 TQ	132	25	129	25	32	108,5
	125	UI 2909 125 TQ	160	25	154	25	33	126,5

UI 2909 ... White zinc plated steel / 1 piece each package + 8 set head screws for fixing to cylinder

Bore mm	Xmax									
	Stroke 50 + 170	Stroke 171 + 420	Stroke 421 + 590	Stroke 591 + 745	Stroke 746 + 900	Stroke 901 + 1130				
50	stroke - 57	stroke - 107	stroke - 147	stroke - 170	stroke - 217	stroke - 249				

Bore mm	Xmax									
	Stroke 50 + 170	Stroke 171 + 220	Stroke 221 + 320	Stroke 321 + 410	Stroke 411 + 510	Stroke 511 + 640	Stroke 641 + 800	Stroke 801 + 950	Stroke 951 + 1100	
63	stroke - 42	stroke - 92	stroke - 132	stroke - 155	stroke - 202	stroke - 234	stroke - 278	stroke - 344	stroke - 432	
80	stroke - 26	stroke - 76	stroke - 116	stroke - 139	stroke - 186	stroke - 218	stroke - 262	stroke - 328	stroke - 416	
100	stroke - 11	stroke - 61	stroke - 101	stroke - 124	stroke - 171	stroke - 203	stroke - 247	stroke - 313	stroke - 401	
125	stroke + 25	stroke - 25	stroke - 65	stroke - 88	stroke - 135	stroke - 167	stroke - 211	stroke - 277	stroke - 365	

If the obtained value of "Xmax" is less than the corresponding value of "Xmin": the adjustable intermediate hinge can not be mounted.

UI 2909 ... TQ (series UT) Adjustable intermediate hinge (MT4)	Bore mm	Code	A3 h14	B4 h14	C3	Ø D3 e9	E3	Xmin	Xmax +
	50	UI 2909 050 TQ	75	16	71	16	20	81	84
	63	UI 2909 063 TQ	90	20	84	20	26	89	96
	80	UI 2909 080 TQ	110	20	105	20	26	99	109
	100	UI 2909 100 TQ	132	25	129	25	32	108,5	124
	125	UI 2909 125 TQ	160	25	154	25	33	126,5	159,5

UI 2909 ... White zinc plated steel / 1 piece each package + 8 set head screws for fixing to cylinder

UI 2909 ... TQ (serie UB) Adjustable intermediate hinge (MT4)	Bore mm	Code	A3 h14	B4 h14	C3	Ø D3 e9	E3	Xmin	Xmax +
	50	UI 2909 050 TQ	75	16	71	16	20	81	40
	63	UI 2909 063 TQ	90	20	84	20	26	89	52
	80	UI 2909 080 TQ	110	20	105	20	26	99	65
	100	UI 2909 100 TQ	132	25	129	25	32	108,5	80
	125	UI 2909 125 TQ	160	25	154	25	33	126,5	115,5

UI 2909 ... White zinc plated steel / 1 piece each package + 8 set head screws for fixing to cylinder

MOUNTING ACCESSORIES

UI 2910 ... Support for intermediate hinge (AT4)	Bore mm	Code	A3 h14	A4	B5	C4	Ø D3 F7	E4 ±0,2	F3 ±0,5	Ø G2 H13	Ø G3 H13	M1	N1 ±0,1
	50	UI 2910 050	75	55	99	117	16	36	9	9	15	36	18
	63	UI 2910 063	90	65	116	136	20	42	11	11	18	40	20
	80	UI 2910 080	110	65	136	156	20	42	11	11	18	40	20
	100	UI 2910 100	132	75	164	189	25	50	13	14	20	50	25
	125	UI 2910 125	160	75	192	217	25	50	13	14	20	50	25

UI 2910 ... White zinc plated steel / 1 piece each package + 8 set head screws for fixing to cylinder

UI SEC ... Pin for female hinge MP2 (AA4)	Bore mm	Code	Ø EK e8	EL ^{+0,3} 0	L
	50	UI SEC 050	12	61	68
	63	UI SEC 063	16	71	78
	80	UI SEC 080	16	91	98
	100	UI SEC 100	20	111	118
	125	UI SEC 125	25	132	139

UI SEC ... White zinc plated steel / 1 piece each package + 2 retaining rings DIN 471

UI SECH ... Pin for female hinge MP6 (AA6)	Bore mm	Code	B	Ø EK f7	EL1 ^{+0,5} ^{+0,3}	H 0 -0,5	L1	Ø P h12	
	50	UI SECH 050	6	0 -1	16	43	20	54	4
	63	UI SECH 063	6		16	49	20	60	4
	80	UI SECH 080	6		20	63	24	75	4
	100	UI SECH 100	6	20	73	24	85	4	
	125	UI SECH 125	9	0 -2	30	94	36	110	6

UI SECH ... White zinc plated steel / 1 piece each package + 1 retaining ring DIN 471

MANUAL REFILL PUMP MRP200

MRP200 Manual oil refill pump	Technical features	
	Code	MRP200
	Threaded connection	Gas 1/4" (ISO 228)
	Pipe length ⁽²⁾	500 mm
	Inside diameter of the pipe	4 mm
	Tank capacity	200 ml

MRP200 / Body in ABS, tank and lever in carbon steel, pipe in Rilsan, NBR seals - 1 piece each package

END OF STROKE SENSORS TYPE SR

SRC-61, SRC-21, SRC-27

End of stroke sensor REED - 2 poles N.O.

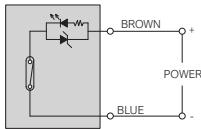
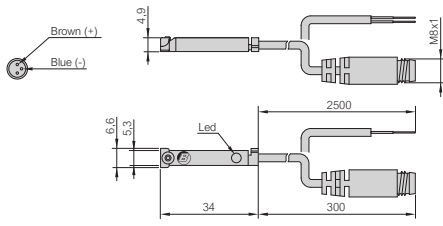

Technical features

Code	SRC-61	SRC-21	SRC-27
Version	Cable 2 x 0,14 mm ²	Cable 2 x 0,14 mm ²	Connector M8 x 1 - 2 pin
Cable length	2500 mm	2500 mm	300 mm
Sensor	REED		
Output	Pure contact, normally open		
Operating voltage	5 ÷ 230 Vac / Vdc	5 ÷ 130 Vac / Vdc	5 ÷ 50 Vac / Vdc
Switching current (max.)	200 mA	200 mA	200 mA
Contact rating (max.)	10 W	6 W	6 W
Voltage drop (max.)	3 V	3 V	3 V
Visual indicator	LED yellow diode		
Operating frequency	1000 Hz		
Working temperature	-15 ÷ +70 °C		
Protection class (IEC 60529))	IP67		
Protection circuit	Power source reverse polarity		
Mounting	Screw for "T" groove - Torque max. 0,15 Nm		

SRC-61, SRC-21, SRC-27 / Sensor in PA6, cable in PUR - 1 piece each package

SRD-21, SRD-27

End of stroke sensor REED - 3 poles N.O.

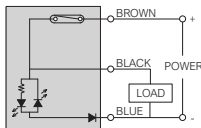
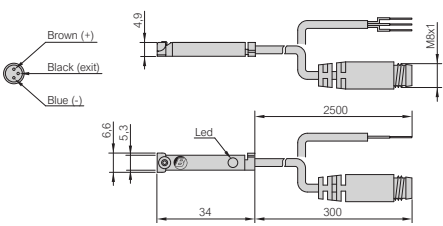

Technical features

Code	SRD-21	SRD-27
Version	Cable 3 x 0,14 mm ²	Connector M8 x 1 - 3 pin
Cable length	2500 mm	300 mm
Sensor	REED	
Output	PNP, normally open	
Operating voltage	5 ÷ 30 Vac / Vdc	
Switching current (max.)	200 mA	
Contact rating (max.)	6 W	
Voltage drop (max.)	0,7 V	
Visual indicator	LED yellow diode	
Operating frequency	1000 Hz	
Working temperature	-15 ÷ +70 °C	
Protection class (IEC 60529))	IP67	
Protection circuit	Power source reverse polarity	
Mounting	Screw for "T" groove - Torque max. 0,15 Nm	

SRD-21, SRD-27 / Sensor in PA6, cable in PUR - 1 piece each package

SRN-21, SRN-27

End of stroke sensor HALL PNP - 3 poles N.O.

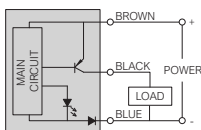
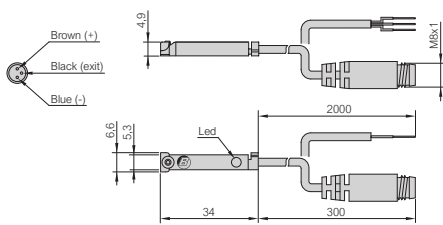

Technical features

Code	SRN-21	SRN-27
Version	Cable 3 x 0,14 mm ²	Connector M8 x 1 - 3 pin
Cable length	2000 mm	300 mm
Sensor	HALL	
Output	PNP, normally open	
Operating voltage	10 ÷ 30 Vdc	
Switching current (max.)	200 mA	
Contact rating (max.)	4 W	
Voltage drop (max.)	0,7 V	
Visual indicator	LED yellow diode	
Operating frequency	1000 Hz	
Working temperature	-15 ÷ +70 °C	
Protection class (IEC 60529))	IP67	
Protection circuit	Power source reverse polarity	
Mounting	Screw for "T" groove - Torque max. 0,15 Nm	

SRN-21, SRN-27 / Sensor in PA6, cable in PUR - 1 piece each package

END OF STROKE SENSORS TYPE SK9 with enclosure classification IP69K
SK9-21

End of stroke sensor HALL PNP - 3 poles N.O.

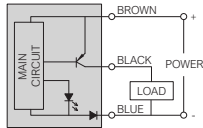
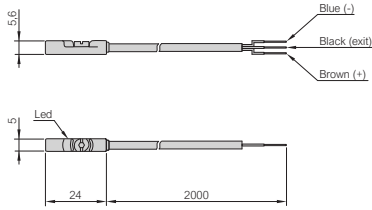

Technical features

Code	SK9-21
Version	Cable 3 x 0,14 mm ²
Cable length	2000 mm
Sensor	HALL
Output	PNP, normally open
Operating voltage	10 ÷ 30 Vdc
Switching current (max.)	200 mA
Contact rating (max.)	6 W
Current consumption	10 mA (without load)
Voltage drop (max.)	2,2 V
Visual indicator	LED yellow diode: flashing (instable position) permanently light (stable position)
Operating frequency	1000 Hz
Temperature range	-30 ÷ +80 °C
Enclosure classification (DIN 40050)	IP69K
Protection circuit	Short-circuit, power source reverse polarity, power-up pulse
Mounting	Screw for "T" groove - Torque max. 0,3 Nm

SK9-21 / Sensor in PA12, cable in PUR - 1 piece each package

END OF STROKE SENSORS TYPE SKC with precise positioning sistem
SKC-27

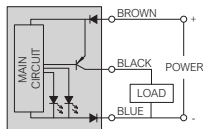
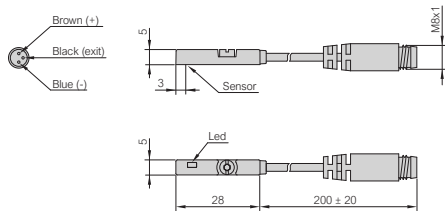
End of stroke sensor HALL PNP - 3 poles N.O.



Technical features

Code	SKC-27
Version	Connector M8 x 1 - 3 pin
Cable length	200 mm
Sensor	HALL
Output	PNP, normally open
Operating voltage	10 ÷ 28 Vdc
Switching current (max.)	80 mA
Contact rating (max.)	2 W
Current consumption	10 mA (24 Vdc)
Voltage drop (max.)	1,5 V
Leakage current (max.)	0,05 mA
Visual indicator	Two colors LED diode: red (instable position) green (stable position)
Operating frequency	1000 Hz
Temperature range	-10 ÷ +60 °C
Enclosure classification (DIN 40050)	IP67
Protection circuit	Short-circuit, power source reverse polarity, power-up pulse
Mounting	Screw for "T" groove - Torque max. 0,3 Nm

SKC-27 / Sensor in PA, cable in PUR - 1 piece each package

THREADED CONNECTORS TYPE Y082LC SUITABLE FOR SRC-27
Y082LC ...

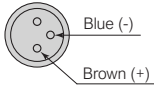
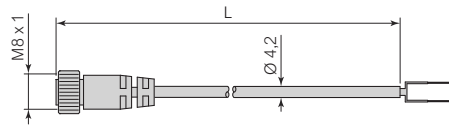
Threaded connectors - 2 poles

Technical features

Code	Y082LC250C	Y082LC500C
Threaded connector	M8 x 1	
End connector	Open	
Cable	2 x 0,14 mm ²	
Cable length (L)	2500 mm	5000 mm
Operating voltage (max.)	50 Vac / 60 Vdc	
Current (max.)	3000 mA	
Working temperature	-25 ÷ +75 °C	
Protection class (IEC 60529)	IP67	

Y082LC ... / Connector in PVC, contacts in gilded brass, cable in PVC - 1 piece each package

THREADED CONNECTORS TYPE Y083LC SUITABLE FOR SRD-27, SRN-27, SKC-27
Y083LC ...

Threaded connectors - 3 poles

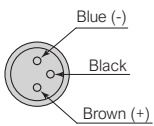
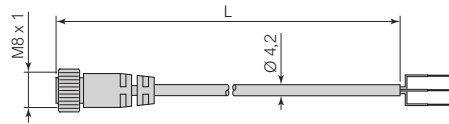
Technical features

Code	Y083LC250D	Y083LC500D
Threaded connector	M8 x 1	
End connector	Open	
Cable	3 x 0,14 mm ²	
Cable length (L)	2500 mm	5000 mm
Operating voltage (max.)	50 Vac / 60 Vdc	
Current (max.)	3000 mA	
Working temperature	-25 ÷ +75 °C	
Protection class (IEC 60529)	IP67	

Y083LC ... / Connector in PVC, contacts in gilded brass, cable in PVC - 1 piece each package

COILS
Y45EG3 ...

Direct current coils

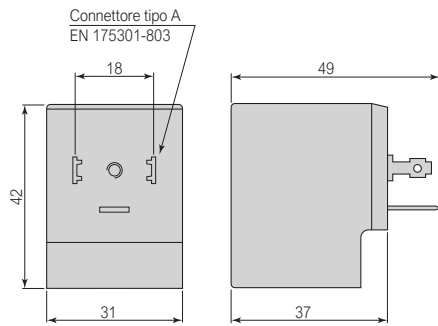

Technical features

Code	Y45EG3 001	Y45EG3 002	Y45EG3 003	Y45EG3 004
Operating voltage	12 VDC	24 VDC	48 VDC	110 VDC
Power consumption (max.)	10 W			
Voltage tolerance	-10% ÷ +15% (of the nominal voltage)			
Encapsulation class	155°C (F)			
Wire insulation class	180°C (H)			
Energising duration	100% (a 20°C)			
Electrical connection	EN175301-803 form A			
Protection class	IP65 (with connector and suitable seals)			
Material	Encapsulated PA 6.6 + Glass fiber			

Y45EG3... / 1 piece each package

Y45EG3 ...

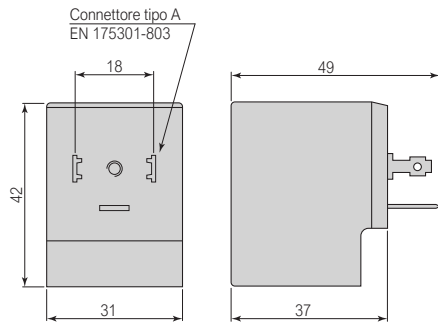
Alternate current coils



Technical features

Code	Y45EG3 005	Y45EG3 006	Y45EG3 007	Y45EG3 008
Operating voltage	24 VAC	48 VAC	110 VAC	220 VAC
Power consumption (max.)	13,5 VA			
Voltage tolerance	-10% ÷ +15% (of the nominal voltage)			
Encapsulation class	155°C (F)			
Wire insulation class	180°C (H)			
Energising duration	100% (a 20°C)			
Electrical connection	EN175301-803 form A			
Protection class	IP65 (with connector and suitable seals)			
Material	Encapsulated PA 6.6 + Glass fiber			

Y45EG3... / 1 piece each package

CONNECTORS for coils type "D" (30 mm)
CNN2...

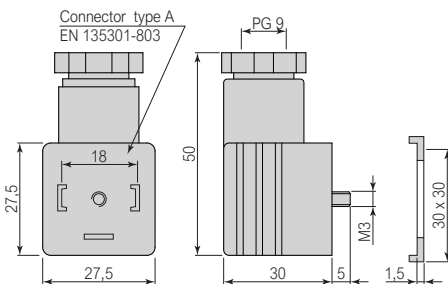
Connectors for coils type "D"



Technical features

Code	CNN2	CNN2 2 LED	CNN2 4 LED	CNN2 5 LED
Operating voltage (max.)	0÷250 V AC/DC	12/24 V AC/DC	115 V AC/DC	230 V AC/DC
Power consumption (max.)	10 A	5 A	5 A	5 A
Contact resistance (max.)	15 mΩ			
Overvoltage category	III			
Conductor size (max.)	1,5 mm ² (without terminals)			
Cable gland	PG9			
Temperature range	-40°C ÷ +100°C	-20°C ÷ +80°C	-20°C ÷ +80°C	-20°C ÷ +80°C
Electrical connection	EN175301-803 type A			
Protection class	IP65 (correctly assembled)			
Material	PA6 GF - PA6 GF	PA6 GF - PA12	PA6 GF - PA12	PA6 GF - PA12
Visual indicator	None	LED yellow diode	LED yellow diode	LED yellow diode
Color	Black	Trasparent	Trasparent	Trasparent
Protection circuit	None	VDR circuit	VDR circuit	VDR circuit
Mounting system	Vite centrale M3x32,5			

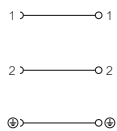
CNN2

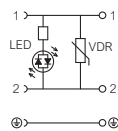

CNN2...LED



CNN2... / Contact holder, housing, seal and mounting screw - 1 piece each package



BONESI PNEUMATIK manufactures all its own products in Italy



BONESI PNEUMATIK s.r.l.

Via A. Robino n. 117
20025 Legnano (MI) Italy
P.I. / C.F. 10396340159
R.E.A. 1373315

www.bonesipneumatik.it
info@bonesipneumatik.it
Phone +39 0331 448000
Telefax +39 0331 448070

