

Unità serie Units series CZ

Regolatore idraulico di velocità Hydraulic speed regulator

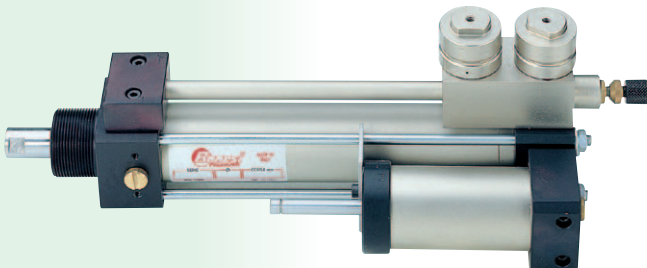

Regolazione con stelo in rientro
Regulation with returning piston rod
cod. **code R**

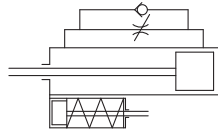

Regolazione con stelo in uscita
Regulation with forwarding piston rod
cod. **code U**

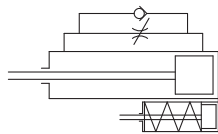

Il regolatore di velocità SERIE CZ è un'apparecchiatura idraulica dinamicamente passiva.

Si applica quando si richiede un moto costante ad una massa in movimento, spinta da un cilindro pneumatico. Può essere accoppiato in parallelo o in asse al cilindro stesso o contrapposto collegato all'organo in movimento.

The CZ SERIES speed regulator is a dynamically passive hydraulic device. It is fitted when a steady movement of a moving mass pushed by a pneumatic cylinder is required. It may be coupled parallel or in line with the unit itself or opposed, connected to the moving body.

Caratteristiche costruttive - Product features

- Camicia in ottone trafilato verniciato esternamente
- Testata in alluminio trafilato e anodizzato
- Stelo in acciaio C45 cromato a spessore
- Tiranti in acciaio zincato
- Guarnizioni in gomma nitrilica antiolio NBR e poliuretano
- Olio circuito idraulico: AGIP ARNICA 22
- Fissaggio standard a musone filettato
- Tiranti sporgenti testata anteriore a richiesta

- Liner made of externally cadmium plated drawn brass
- End cap made of anodized drawn aluminium
- Piston rod made of Hard chrome plated C45 steel
- Tie rods in cadmium plated steel
- Pneumatic gaskets made of NBR anti-oil nitrile rubber and polyurethane
- Hydraulic circuit oil: AGIP ARNICA 22
- Standard fixing by threaded nose
- Front end cap projecting tie rods upon request

Dati tecnici - Technical data

- Forza frenante: max. 800 daN - min. 30 daN
- Campo di regolazione velocità: min. 40 mm/min - max. 12 m/min
- Temperatura: - 20°C + 60°C
- Braking power: max. 800 daN- min. 30 daN
- Speed regulation range: min. 40 mm/minute max. 12 m/minute
- Temperature: - 20°C + 60°C

Funzioni standard - Standard functions

- Singola regolazione
- Doppia regolazione: in uscita ed in rientro
- Valvola di SKIP - Comando pneumatico
- Valvola di STOP - Comando pneumatico
- Single adjustment
- Double adjustment: thrusting and pulling
- Skip valve – pneumatic governor
- STOP valve – pneumatic governor

Disegno schematico di funzionalità - Schematic operating diagram

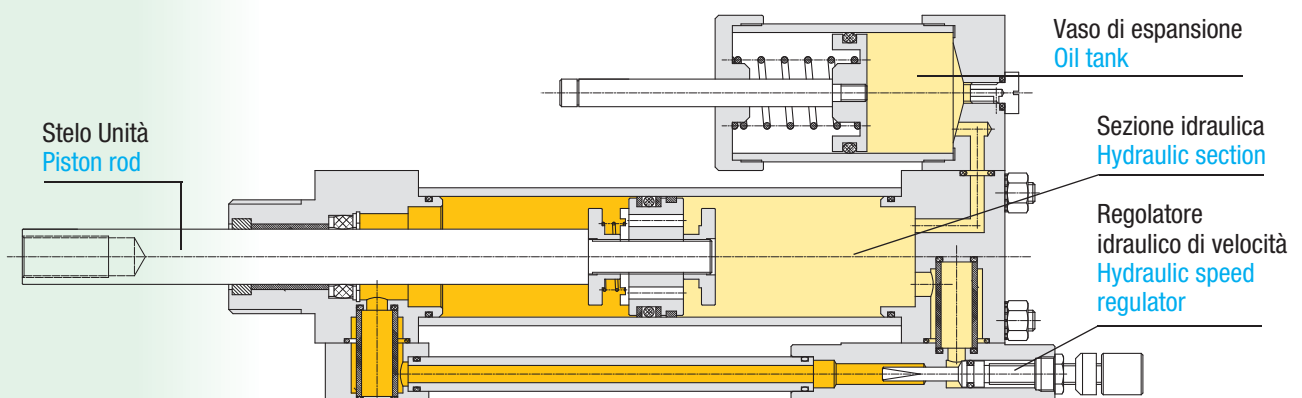

Dimensioni comuni - Common dimensions

Corse disponibili - Available strokes : mm 50 - 100 - 150 - 200 - 250 - 300 - 350 - 400 - 450 - 500

Unità regolata su corsa in uscita - Speed regulation on forward stroke

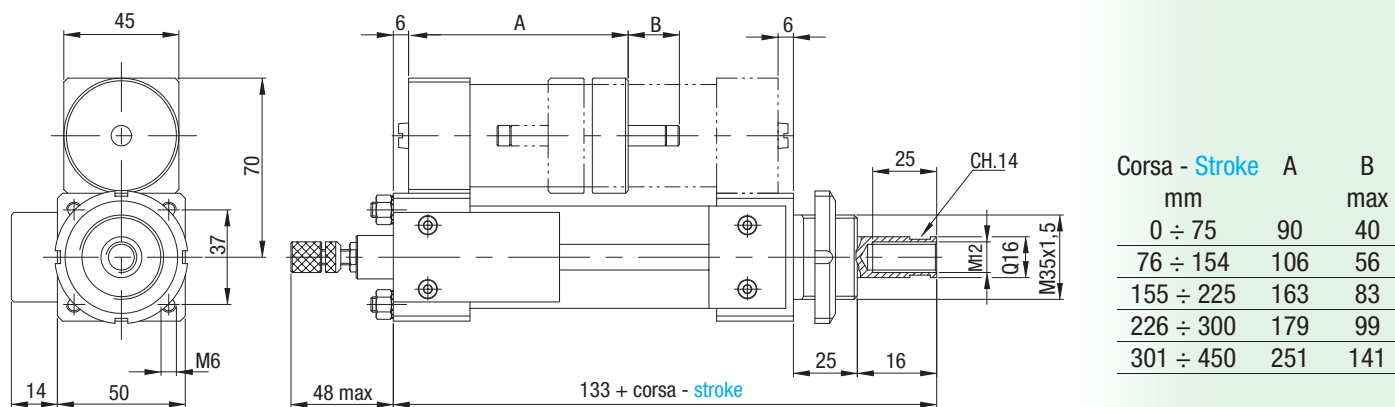

Unità regolata su corsa in uscita + SKIP/STOP - Speed regulation on forward stroke + SKIP/STOP

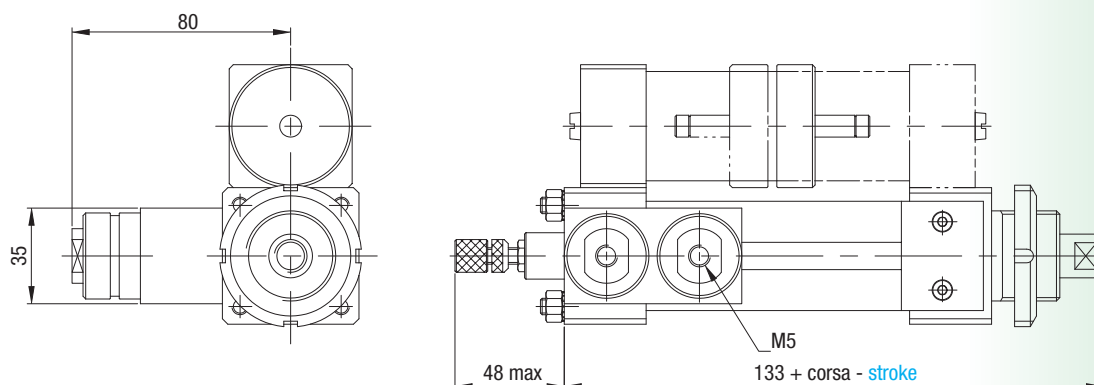

Unità regolata su corsa in uscita e in rientro - Speed regulation on both, forward and return stroke

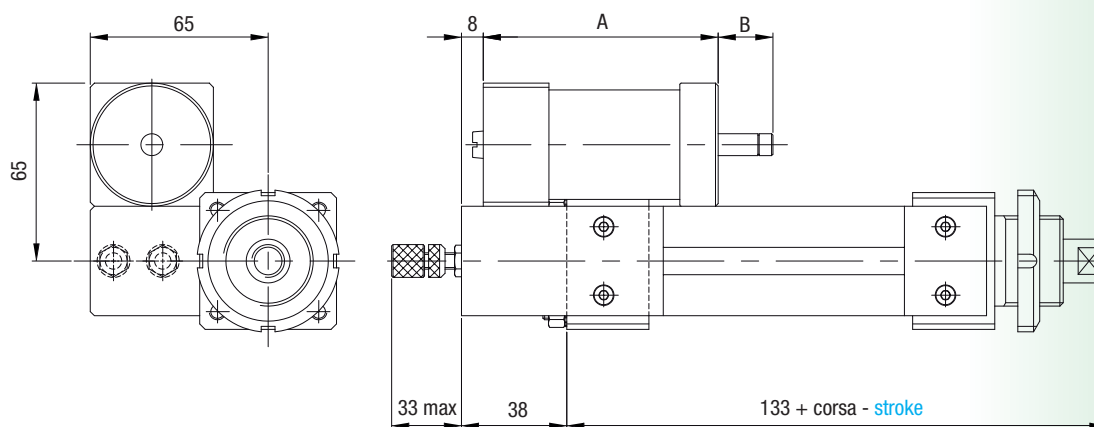

Codici per l'ordinazione - Order codes

Regolato in uscita	Regolato in uscita+stop	Regolato in uscita+skip	Regolato in uscita+stop+skip	Regolato in rientro	Regolato in rientro+stop	Regolato in rientro+skip	Regolato in rientro+stop+skip	Doppia regolazione
Forward stroke regulation	Forward stroke regulation + stop	Forward stroke regulation + skip	Forward stroke regulation + stop + skip	Return stroke regulation	Return stroke regulation + stop	Return stroke regulation + skip	Return stroke regulation +stop +skip	Double regulation
CZ35U1	CZ35U2	CZ35U3	CZ35U4	CZ35R1	CZ35R2	CZ35R3	CZ35R4	CZ35D1